

Safety solutions using Preventa

Categories of safety-related parts of control systems according to EN 954-1

Preparation of a safety circuit

The main aim of the designer is to ensure that a dangerous situation cannot be created on the machine by the failure of parts of a control system relating to safety or by external factors.

The chart below makes it possible to determine the categories of parts of control systems.

Categories	Basic safety principle	Control system requirements	Behaviour in the event of a fault
B	Selection of components that conform to relevant standards	Control in accordance with good engineering practice.	Possible loss of safety function.
1	Selection of components and basic safety principles	Use of tried and tested components and proven safety principles.	Possible loss of safety function, but with less probability of this than with B .
2	Selection of components and basic safety principles	Cyclic testing. The test intervals must be suited to the machine and its applications.	Fault detected at each test.
3	Structure of the safety circuits	A single fault must not cause loss of the safety function. This single fault must be detected if reasonably practicable.	Safety function ensured, except in the event of an accumulation of faults.
4	Structure of the safety circuits	A single fault must not cause loss of the safety function. This fault must be detected at or before the next demand on the safety function. An accumulation of faults must not cause loss of the safety function.	Safety function always ensured.

Safety solutions using Preventa

Categories of safety-related parts of control systems according to EN 954-1

The more the risk reduction depends on the safety-related parts of a control system, the more those parts need to be resistant to faults.

Comments :

- **Self-monitoring** is one of the methods which can be used to create a **category 2** control system.
- **Redundancy** is one of the methods which can be used to create a **category 3** control system.
- **The combination of redundancy and self-monitoring** is one of the methods which can be used to create a **category 4** control system.
- Redundancy and self-monitoring are described in detail on page 38106/4.
- **It is recommended that the N/C auxiliary contacts 21-22 , present on K and D range contactors, be used in the feedback loop of the safety modules.**
These auxiliary contacts are in fact mechanically linked with the power contacts of the contactor and consistency of state is guaranteed in the event of welding (see coordination of protective devices, page 38106/5) of the power poles following a short-circuit.

Typical structure of a safety circuit in the event of a fault

Practical examples of safety circuits

Comments

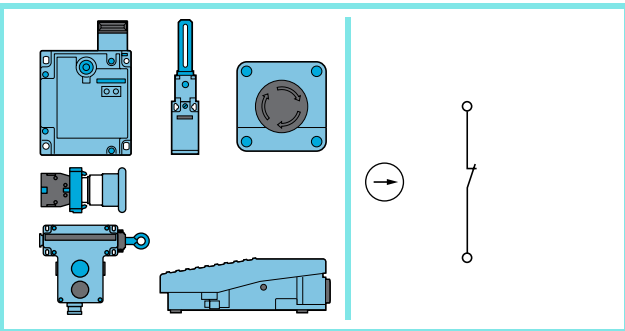
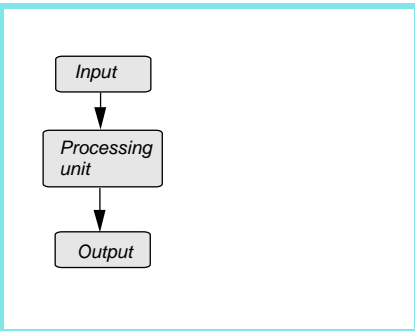

- No redundancy on the input (control).
- No internal redundancy provided by the relay.
- No redundancy on the output.

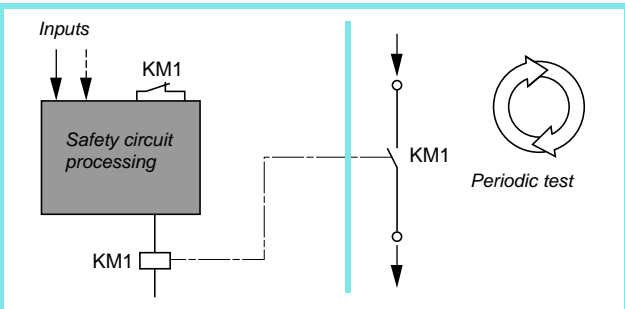
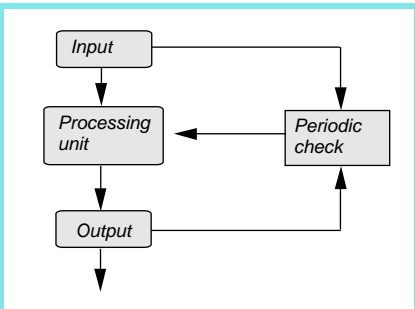

- Redundancy or no redundancy on the inputs.
- The feedback loop allows a cyclic test to be carried out on the output (interval to be determined according to the application).

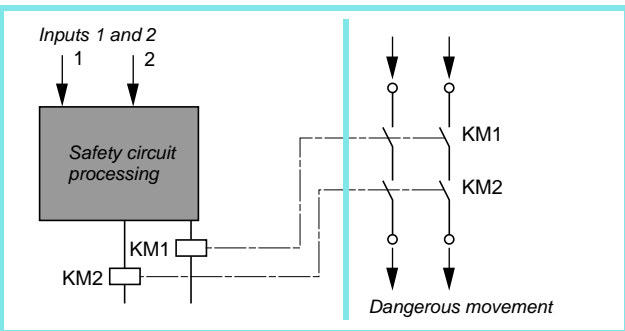
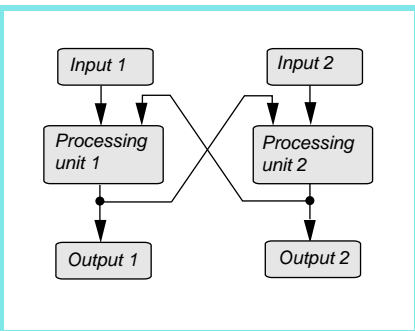

- Redundancy on the inputs.
- Redundancy on the outputs.

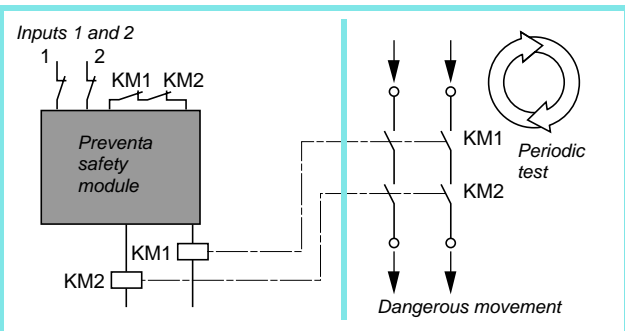
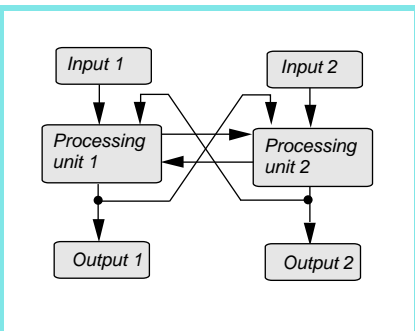

- Redundancy on the inputs.
- Redundancy on the outputs.
- The feedback loop allows continuous monitoring of the outputs.

Safety solutions using Preventa

Control system categories in accordance with EN 954-1

This is an application standard for the preparation of "C" type standards

Safety related parts of control systems

EN 954-1 covers the "Principles for Design of safety related parts of control systems". It does not cover their detailed design. The main aim of the designer is to ensure that a dangerous situation cannot be created on the machine due to failure within the control system, or by external factors.

EN 954-1 helps a designer select a control system category according to the risk reduction required and the consequences of a fault, based on the expected system behaviour.

Control system categories related to safety	Control system requirements	Control system behaviour in the event of a fault
B	Manufactured to European standards to withstand expected influences	Possible loss of safety function
1	As B: plus Use of well tried and tested components and safety principles	Greater reliability, but possible loss of safety function
2	As B and 1: plus Cyclic testing (frequency determined according to application)	Fault detected at each test (possible loss of safety function between checks)
3	As B and 1: plus A single fault must not cause loss of the safety function. The fault must be detected whenever reasonably practicable	Safety function ensured, except in the event of an accumulation of faults (Not all faults will be detected)
4	As B and 1: plus A single fault must not cause loss of the safety function. The fault must be detected at or before the next call on the safety system. An accumulation of faults must not cause loss of the safety function	Safety function ensured Faults will be detected in time to prevent the loss of the safety function

The integrity of the control system must be assessed in conjunction with the overall safety strategy for the machine to ensure that the required safety performance is achieved.

Table linking risks and recommended categories

(Table attached as appendix to standard EN 954-1)

Practical method for recommending a category for components in a control system according to previously estimated factors: S, F, P.

S	Result of the accident
S1	Slight injury
S2	Serious and permanent injury to or death of the person
F	Presence in the danger zone
F1	Rare to fairly frequent
F2	Frequent to permanent
P	Possibility of preventing the accident
P1	Possible in certain circumstances
P2	Virtually impossible

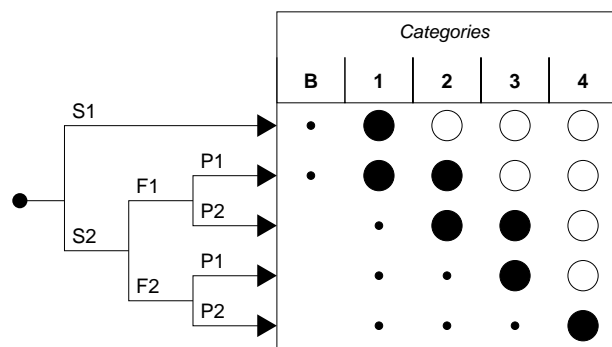

- Preferred category
- Measures exceeding min. requirements for risk involved
- Possible category requiring additional measures

Safety solutions using Preventa

Selection of type of protection, conforming to standard EN/ISO 12100

Different types of protection

The application of standard EN/ISO 12100 may lead to the selection of:

- **individual** type protection (for example, two-hand control),
- or **collective** type protection (for example, safety light curtain).

Individual protection device

Example: use of a two-hand control station

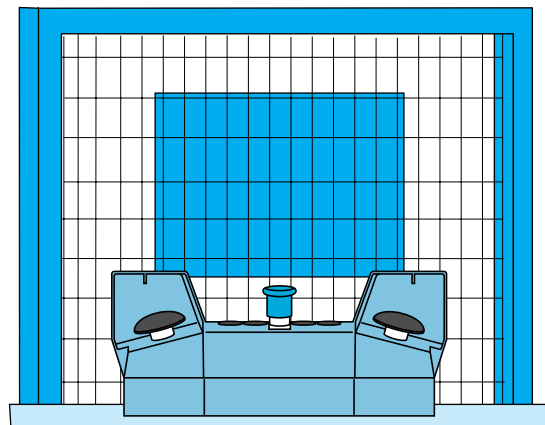
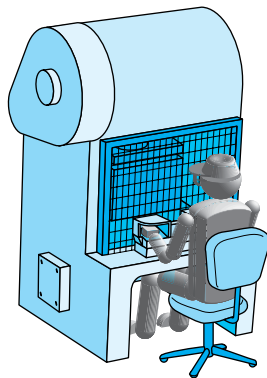

Collective protection device

Example: use of a safety light curtain

Access to the danger zone round the machine is denied to **all persons** approaching it, and not just the operator.

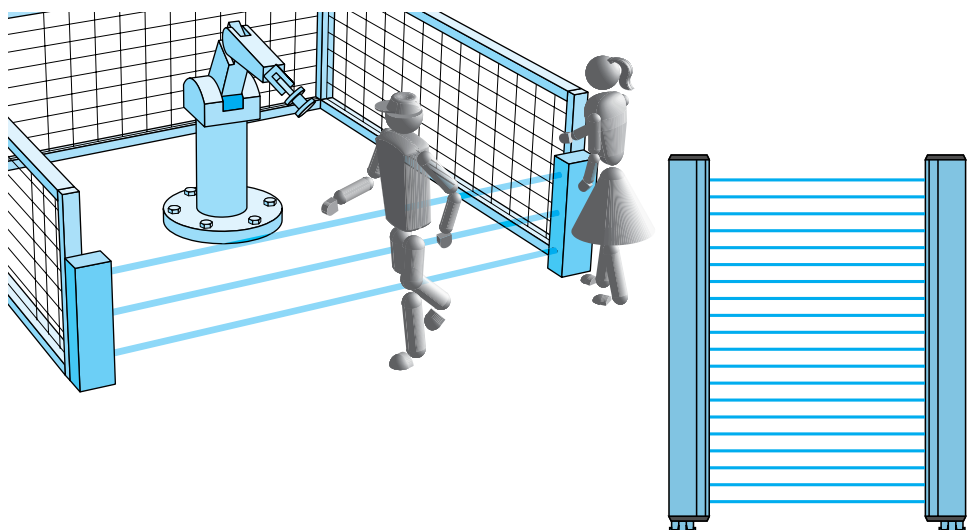

Safety solutions using Preventa

Practical examples of safety power circuits according to application requirements and categories of EN 954-1

Single-motor starters

Categories B, 1 and 2

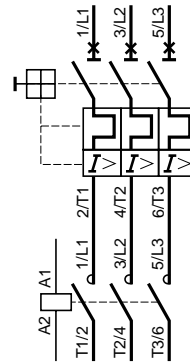

1 circuit breaker + 1 contactor

Categories 3 and 4

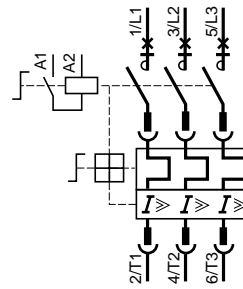

1 integral contactor breaker

Multiple-motor starters

Categories 3 and 4

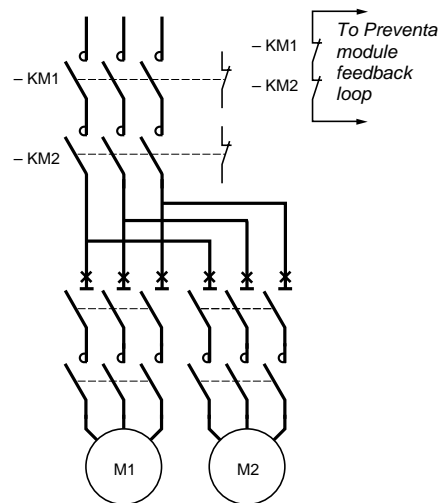

2 line contactors in redundant mode

OR

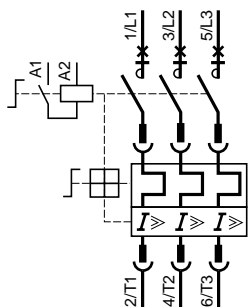

1 integral contactor breaker

OR

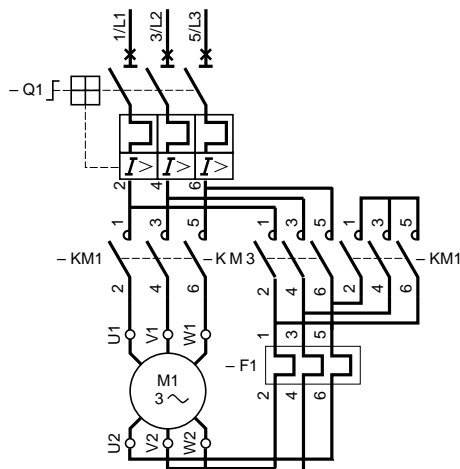

1 circuit breaker + 1 star delta starter

OR

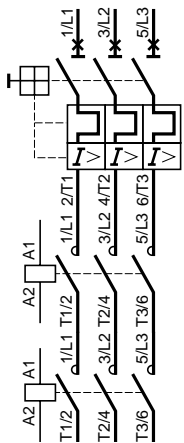

1 circuit breaker + 2 contactors in series

OR

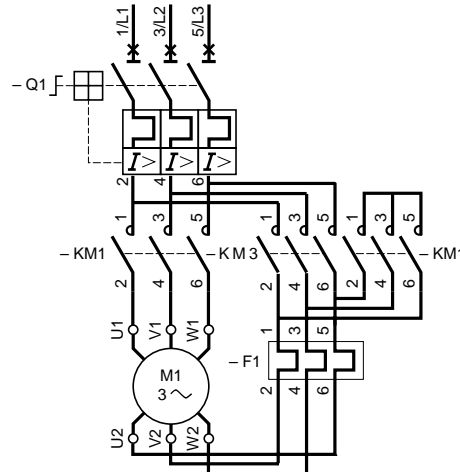

1 circuit breaker + 1 star delta starter (1)

OR

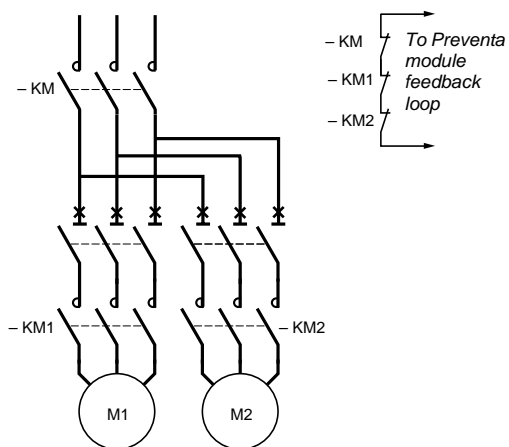

1 line contactor and 1 subsidiary contactor in redundant mode

OR

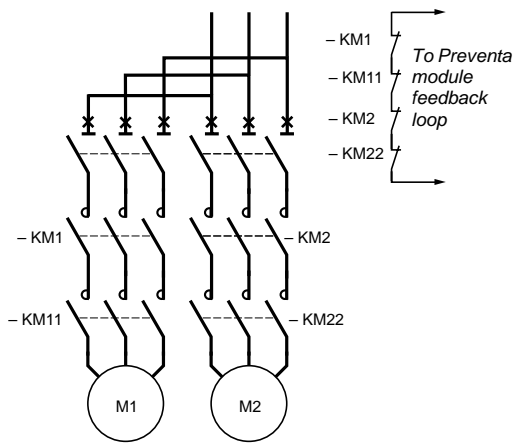

2 subsidiary contactors in redundant mode

(1) For this type of starting, redundancy does not require the installation of an additional contactor because:

- there are already, in principle, 2 contactors in series,
- the 3 contactors are of identical rating,
- protection has been selected so as to achieve type 2 coordination.

Safety solutions using Preventa

Examples of typical applications

Emergency Stop Monitoring

(Example of Emergency Stop circuit in category 3 conforming to EN 954-1)

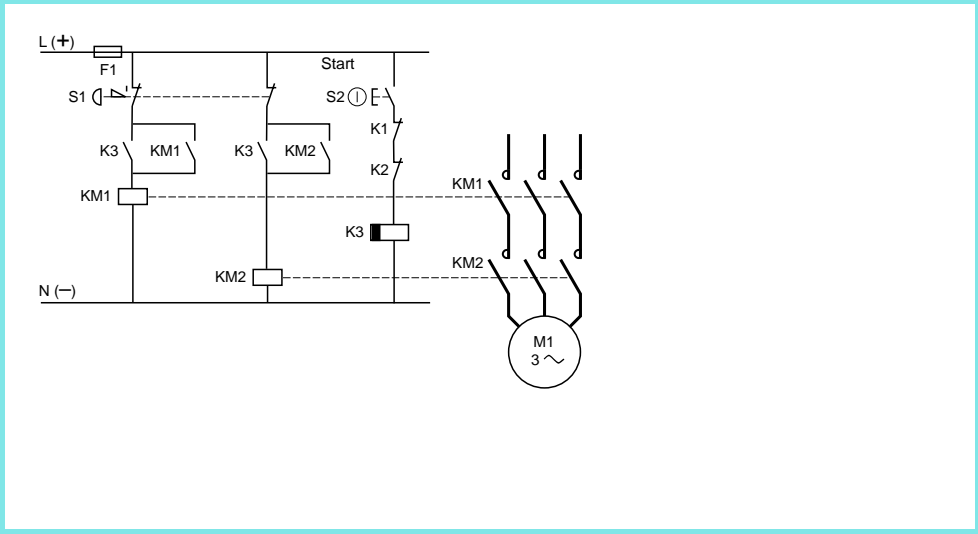

Motor control

(Example of mixed redundancy for an emergency stop in an application with several motors and one PLC)

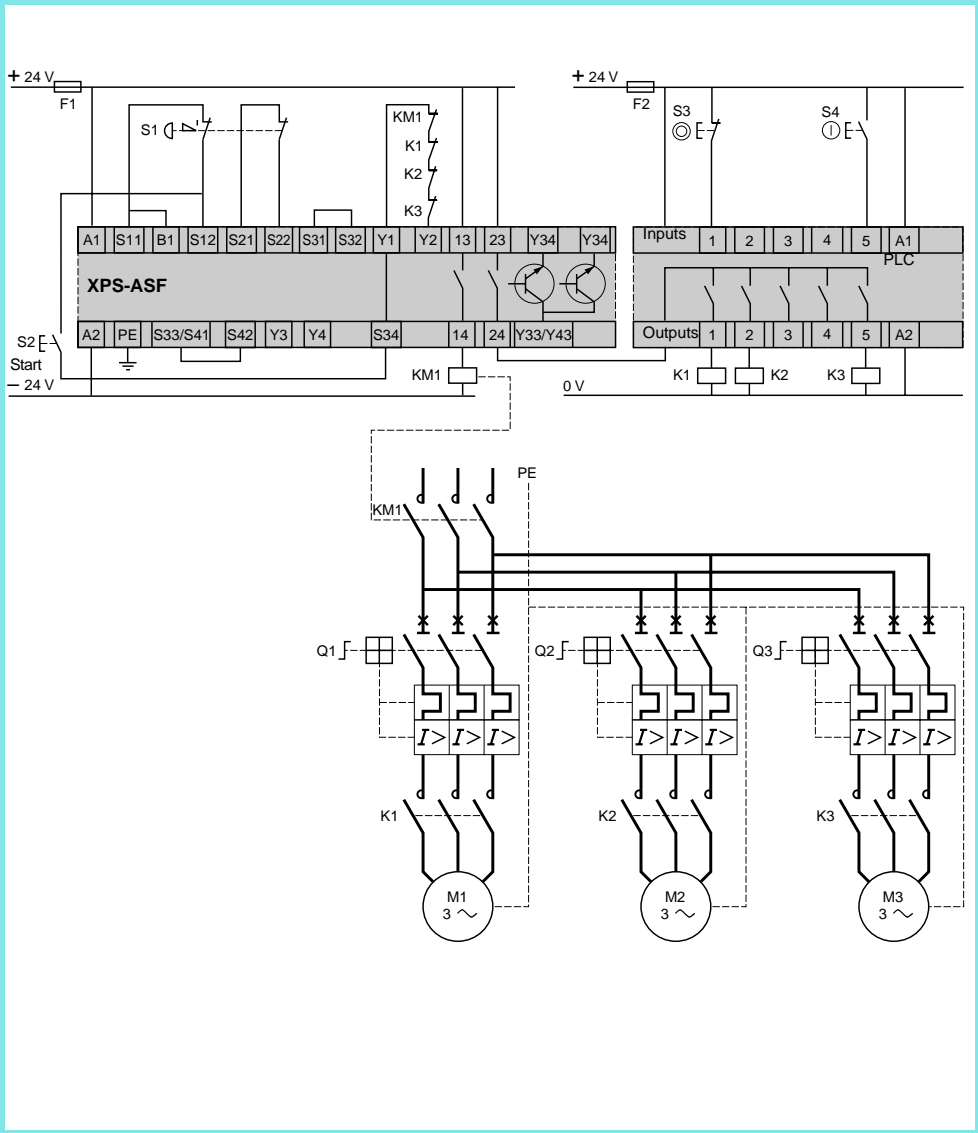

Safety solutions using Preventa

Examples of typical applications

Control with variable speed controller

(Example of safety circuit combining an Emergency stop module controlled in accordance with standard EN 418 (stop category 1) and a variable speed drive)

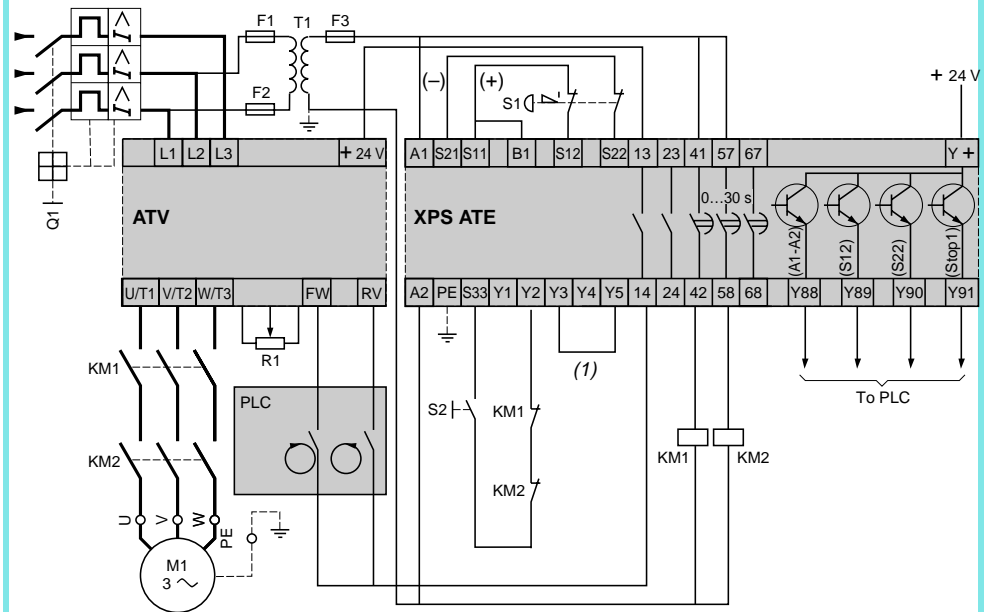

(1) With Start button monitoring

S1: Emergency Stop button with 2 N/C contacts (recommended application)