

Practical advice

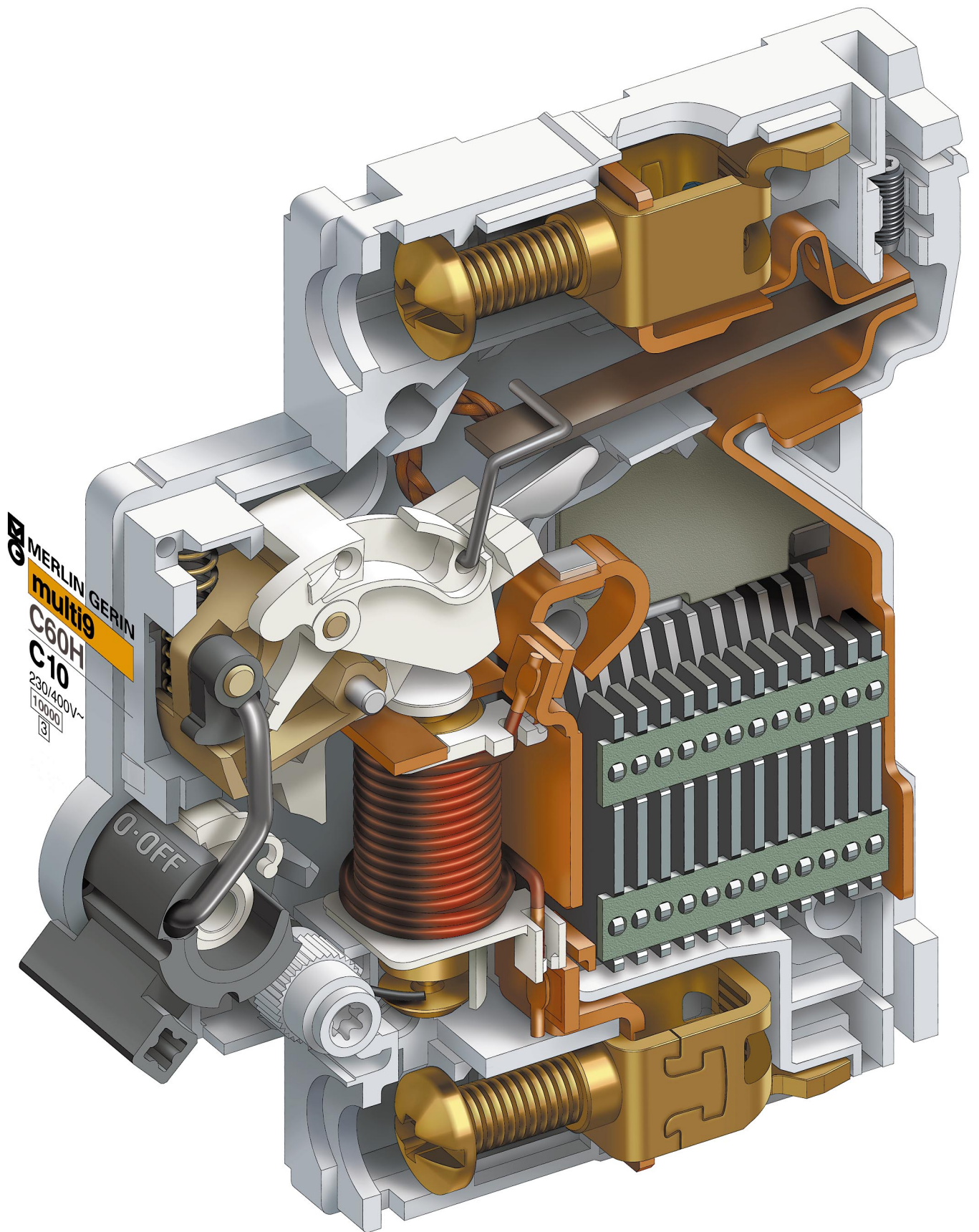

	<i>Page</i>
OF contact and SD switch	66
tripping curves	68
thermal stress/peak current limitation curves	69
cascading	71
discrimination	73
temperature derating	77
power loss	78
use in 400 Hz	79
CT contactors	80
impulse relays	82
circuit breaker for DC applications	83
coordination	84
modular switchgear dimensions	86
modular enclosure dimensions	90

OF contact and SD switch, MX+OF, MN and MN releases

for C60,C120 circuit-breakers
and RCCB residual current circuit-breakers

SD fault indicating switch

application

- audible or visual indication of circuit-breaker tripped status: climatic room, lift, ventilation, etc.
- front face indication of contact status (red mechanical indicator) and of the "fault clearance" function
- optional resetting of indication separately from the circuit-breaker
- optional testing of contact on front face, with the circuit-breaker open.

circuit-breaker	SD switch position
-----------------	--------------------

open	91-94
closed	91-94
tripped	91-92

connection

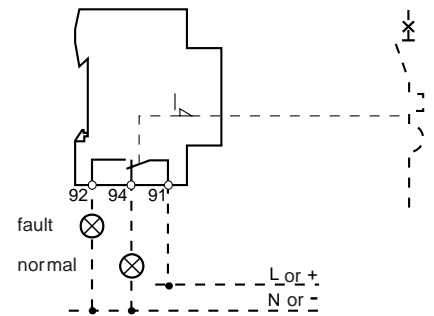

OF + SD/OF changeover auxiliary switch

application

- double changeover switch:
 - the top switch indicates the "open" or "closed" status of the circuit-breaker
 - the bottom switch indicates according to user choice:
 - the "open" or "closed" status (OF)
 - the "tripped" status (SD)
- front face indication of the tripped status, by red mechanical indicator (regardless of lateral selector switch position)
- optional testing of the bottom switch (SD changeover) on the front face, with the circuit-breaker open
- optional resetting of indication separately from the circuit-breaker.

circuit-breaker	OF contact position	
-----------------	---------------------	--

open	11-12	21-22
closed	11-14	21-24
tripped	11-12	21-22

circuit-breaker	SD switch position
-----------------	--------------------

open	91-94
closed	91-94
tripped	91-92

connection

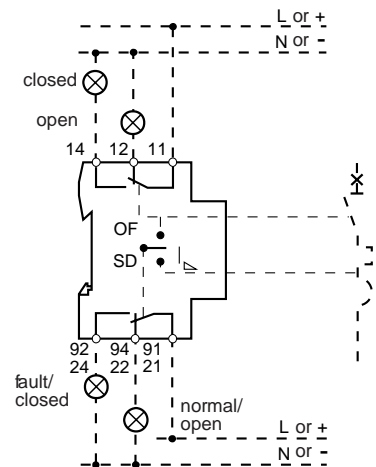

shunt release

MX + OF

application

- remote opening by circuit-breaker tripping, of electrical lighting circuits, etc.
- terminals 12 and 14 are used for indication of the circuit-breaker OF position, at a voltage identical to coil voltage
- indication on the front face of the tripped function, by a red mechanical indicator.

connection

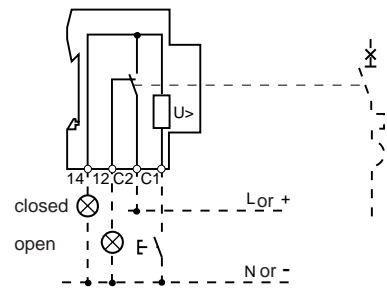

undervoltage release

MN or MN S

application

- opening of electrical circuits by circuit-breaker tripping:
 - either by emergency stopping (mushroom head pushbutton)
 - or on mains failure
- impossibility of uncontrolled restart is particularly recommended in two cases cases, thus guaranteeing complete safety:
 - when the machine operator is confronted with a risk of untimely restart: circular saw, rotating machine, etc.
 - when it is necessary to control restart of an installation further to a mains failure.
- indication on the front face of the tripped function, by a red mechanical indicator
- the MN coil is accepted as an emergency stopping device by the installation standard. However it does not indicate circuit-breaker OF position.

connection

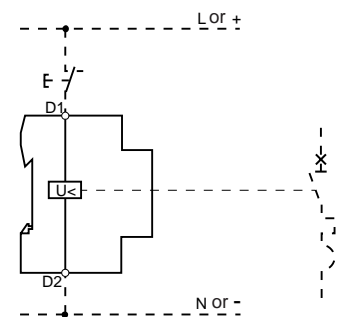

practical advice
tripping curves

C60 circuit-breaker

B, C and D curves, as in standard 60898
 The operating range of the magnetic release is as follows:
 ■ for B curve: between 3 I_n and 5 I_n
 ■ for C curve: between 5 I_n and 10 I_n
 ■ for D curve: between 10 I_n and 14 I_n
 The curves show the cold thermal tripping limits when poles are charged and the electromagnetic tripping limits with 2 charged poles.

C60 B curve

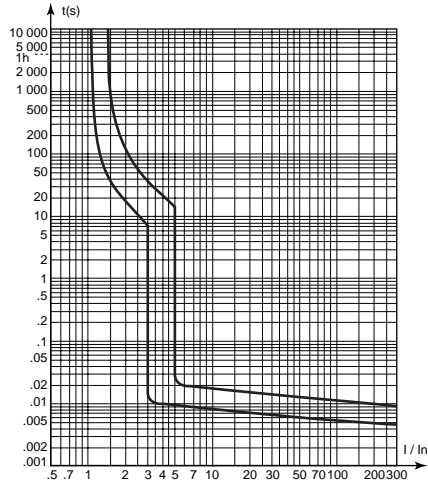

C60 C curve

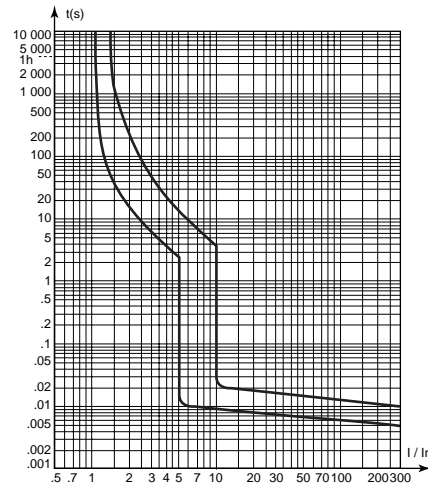

C60 D curve

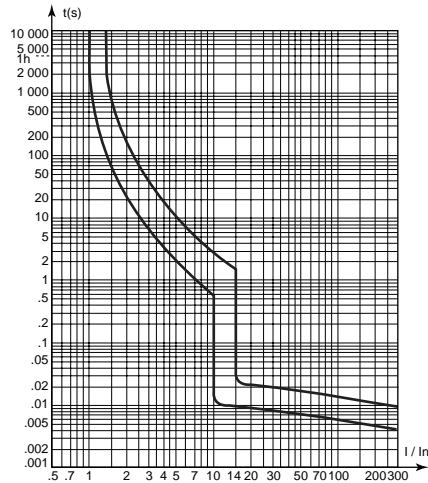

C120N circuit-breaker

C curves, as in standard EN 60898 (NF C 61-410)
 The operating range of the magnetic release is as follows:
 ■ for B curve: between 3 I_n and 5 I_n
 ■ for C curve: between 5 I_n and 10 I_n
 ■ for D curve: between 10 I_n and 14 I_n
 The curves show the cold thermal tripping limits when poles are charged and the electromagnetic tripping limits with 2 charged poles.

C120N B curve

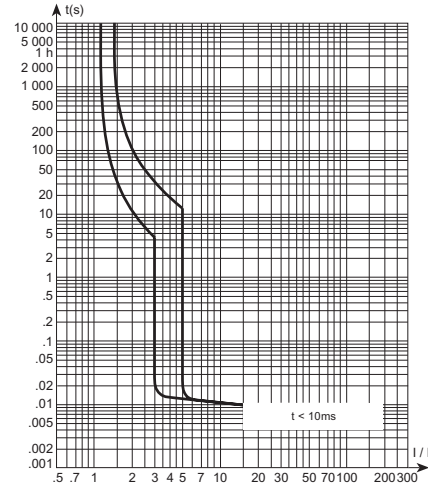

C120N C curve

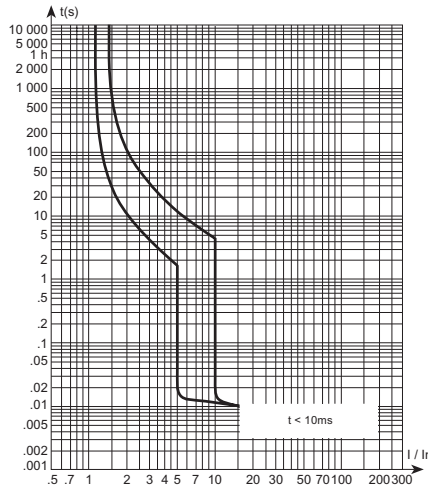

C120N D curve

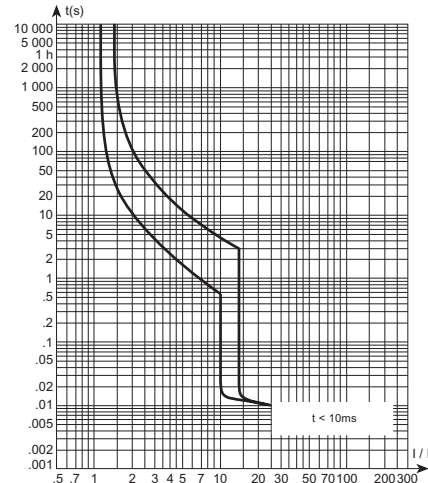

NC100 circuit-breaker

C curve as in standard IEC 60947.2
 The operating range of the magnetic release is as follows:
 ■ for C curve: between 7 I_n and 10 I_n
 The curves show the cold thermal tripping limits when poles are charged and the electromagnetic tripping limits with 2 charged poles.

NC100 C curve

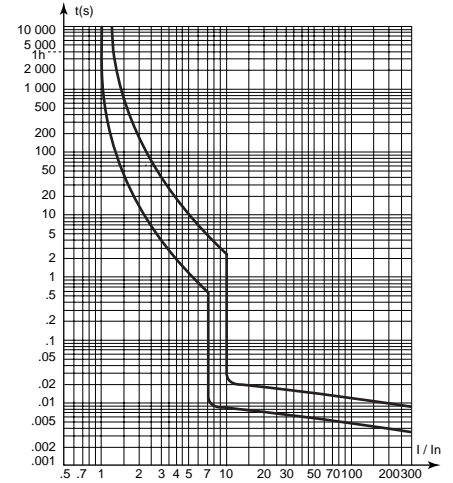

thermal stress and peak current limitation curves

thermal stress limitation

C60H B curve 240/415 V

- Ue:
- 240 V with 1P
- 415 V with 2, 3, 4P
- circuit-breaker type in accordance with the mark:
- 3: C60H

limited thermal stress

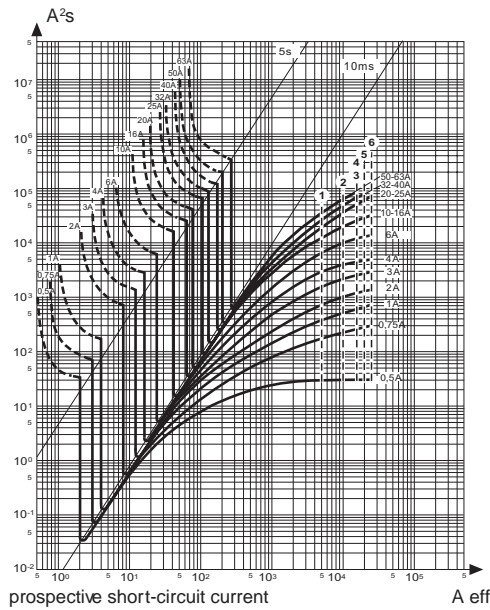

C60H C curve 240/415 V

- Ue:
- 240 V with 1P
- 415 V with 2, 3, 4P
- circuit-breaker type in accordance with the mark:
- 3: C60H

limited thermal stress

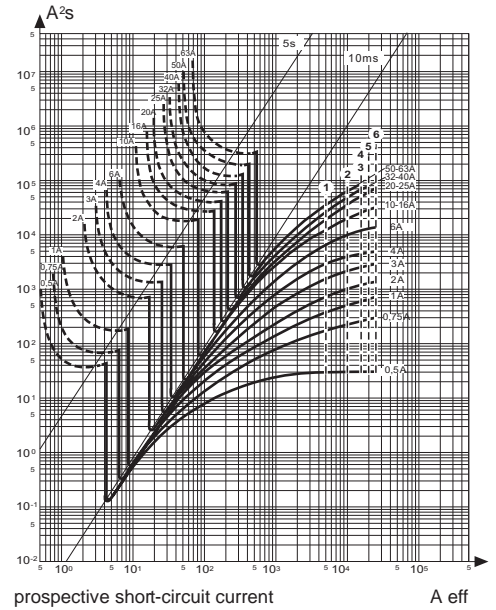

C60H D curve 240/415 V

- Ue:
- 240 V with 1P
- 415 V with 2, 3, 4P
- circuit-breaker type in accordance with the mark:
- 3: C60H

limited thermal stress

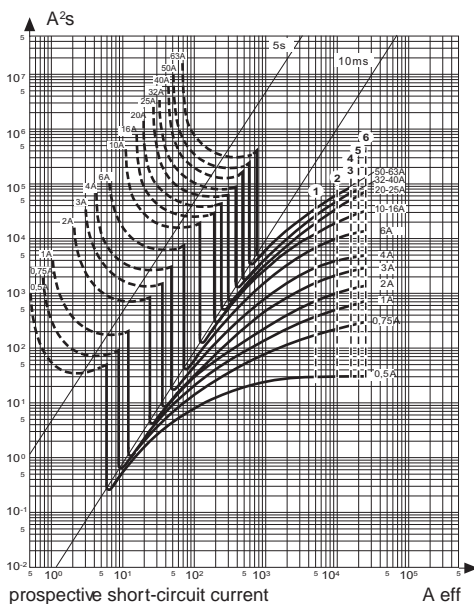

C60H 240/415 V

- Ue:
- 240 V with 1P
- 415 V with 2, 3, 4P
- 415 V C60LMA with 2, 3P
- circuit-breaker type in accordance with the mark:
- 3: C60N

limited peak current

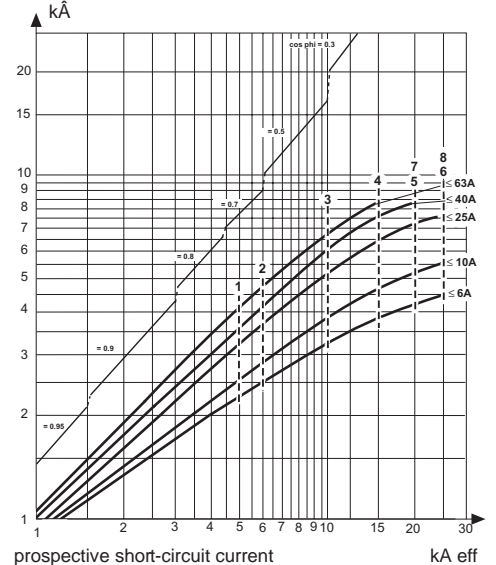

thermal stress and peak current limitation curves

thermal stress limitation

C120N, H C curve 240/415 V

- Ue:
 - 240 V with 1P
 - 415 V with 2, 3, 4P
- circuit-breaker type in accordance with the mark:
 - 1: C120N
 - 2: C120H

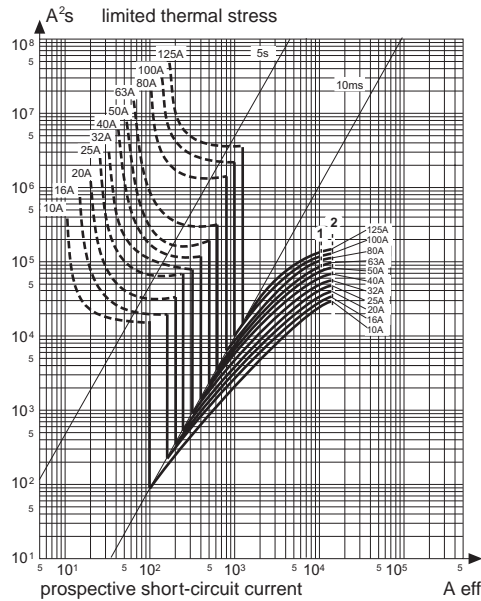

peak current limitation

C120N, H 240/415 V

- Ue:
 - 240 V with 1P
 - 415 V with 2, 3, 4P
- circuit-breaker type in accordance with the mark:
 - 1: C120N
 - 2: C120H

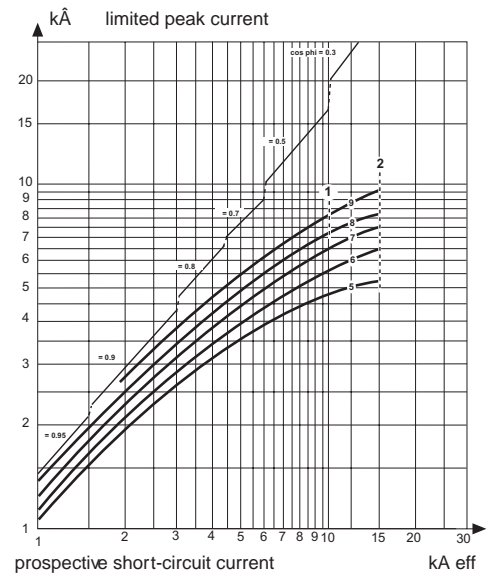

what is cascading?

Cascading is the use of the current limiting capacity of circuit breakers at a given point to permit installation of lower-rated and therefore lower-cost circuit breakers downstream.

The upstream Compact circuit breaker acts as a barrier against short-circuit currents. In this way, downstream circuit breakers with lower breaking capacities than the prospective short-circuit (at their point of installation) operate under their normal breaking conditions.

Since the current is limited throughout the circuit controlled by the limiting circuit breaker, cascading applies to all switchgear downstream. It is not restricted to two consecutive devices.

general use of cascading

With cascading, the devices can be installed in different switchboards. Thus, in general, cascading refers to any combination of circuit breakers where a circuit breaker with a breaking capacity less than the prospective I_{sc} at its point of installation can be used. Of course, the breaking capacity of the upstream circuit breaker must be greater than or equal to the prospective short-circuit current at its point of installation.

The combination of two circuit breakers in cascading configuration is covered by the following standards:

- IEC 60947-2 (construction);
- NF C 15-100, § 434.3.1 (installation).

coordination between circuit breakers

The use of a protective device possessing a breaking capacity less than the prospective short-circuit current at its installation point is permitted as long as another device is installed upstream with at least the necessary breaking capacity.

In this case, the characteristics of the two devices must be coordinated in such a way that the energy let through by the upstream device is not more than that which can be withstood by the downstream device and the cables protected by these devices without damage.

Cascading can only be checked by laboratory tests and the possible combinations can be specified only by the circuit breaker manufacturer.

220/240 V network downstream from a 380/415 V network

For 1P + N or 2P circuit breakers connected between the phase and neutral on a 380/415 V network, with a TT or TNS neutral system, consult the 220/240 V cascading table to determinate cascading possibilities between upstream and downstream circuit breakers.

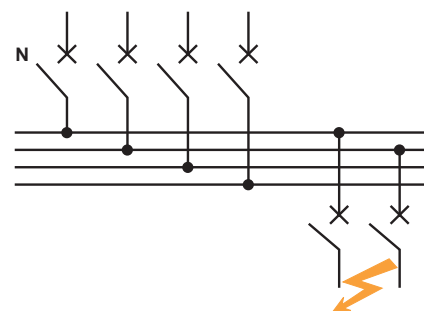

economy by means of cascading

Thanks to cascading, circuit breakers with breaking capacities less than the prospective short-circuit current may be installed downstream from a current limiting circuit breaker.

It follows that substantial savings can be made on downstream switchgear and enclosures. The example below illustrates this possibility.

cascading tables

Merlin Gerin cascading tables are:

- drawn up on the basis of calculations (comparison between the energy limited by the upstream device and the maximum permissible thermal stress for the downstream device);

- verified experimentally in accordance with IEC standard 60947-2.

For distribution systems with 220/240 V 400/415 V and 440 V between phases, the tables of the following pages indicate cascading possibilities between upstream Compact and downstream Multi 9 and Compact circuit breakers as well as between upstream Masterpact and downstream Compact circuit breakers.

example of three level cascading

Consider three circuit breakers **A**, **B** and **C** connected in series. The criteria for cascading are fulfilled in the following two cases:

- the upstream device **A** is coordinated for cascading with both devices **B** and **C** (even if the cascading criteria are not fulfilled between **B** and **C**). It is simply necessary to check that the combinations **A + B** and **A + C** have the required breaking capacity;
- each pair of successive devices is coordinated, i.e. **A** with **B** and **B** with **C** (even if the cascading criteria are not fulfilled between **A** and **C**). It is simply necessary to check that the combinations **A + B** and **B + C** have the required breaking capacity.

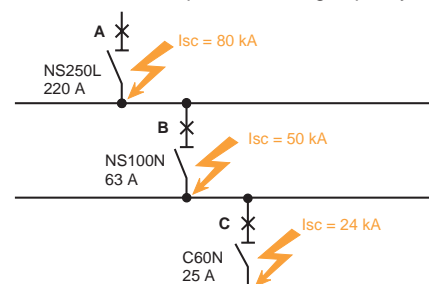

The upstream breaker **A** is a NS250L (breaking capacity 150 kA) for a prospective I_{sc} of 80 kA across its output terminals. A NS100N (breaking capacity 25 kA) can be used for circuit breaker **B** for a prospective I_{sc} of 50 kA across its output terminals, since the "reinforced" breaking capacity provided by cascading with the upstream NS250L is 150 kA.

A C60N (breaking capacity 10 kA) can be used for circuit breaker **C** for a prospective I_{sc} of 24 kA across its output terminals since the "reinforced" breaking capacity provided by cascading with the upstream NS250L is 30 kA.

Note that the "reinforced" breaking capacity of the C60N with the NS100N upstream is only 25 kA, but:

- **A + B** = 150 kA;
- **A + C** = 30 kA.

cascading 230...240 V

upstream: multi 9
downstream: multi 9
reinforced breaking capacity (kA)

upstream	C60H	C120	NC100L	NC100LH
downstream	15	15	25	50
rated breaking capacity				
C60H 15	15	15	25	50
C120N 15	15	15	25	50
NC100L 25			25	50
NC100LH 50				50

upstream: Compact NS
downstream: multi 9
reinforced breaking capacity (kA)

upstream	NS100N	NS100H	NS160N	NS160H	NS250N	NS250H
downstream	85	100	85	100	85	100
rated breaking capacity						
C60H 30	50	100	50	100	50	65
C120 30	50	100	50	100	50	65
NC100L 50	60	70	60	70	60	70
NC100LH 100		100		100		100

cascading 400...415 V

upstream: multi 9
downstream: multi 9
reinforced breaking capacity (kA)

upstream	C60H	C120	NC100L	NC100LH
downstream	30	30	50	100
rated breaking capacity				
C60H 30	30	30	50	100
C120N 30	30	30	50	100
NC100L 50			50	100
NC100LH 100				100

upstream: Compact NS
downstream: multi 9
reinforced breaking capacity (kA)

upstream	NS100N	NS100H	NS160N	NS160H	NS250N	NS250H
downstream	25	70	36	70	36	70
rated breaking capacity						
C60H 15	25	40	30	30	30	30
C120N 15	25	40				
NC100L 25		50		50		50
NC100LH 50		70		70		70

Protection discrimination is an essential element that must be taken into account when starting to design a low voltage installation, ensuring the highest level of protection for users.

Discrimination is important in all installations for the comfort of users, however it is fundamental in installations requiring a high level of service continuity, e.g. industrial manufacturing processes.

Industrial installations without discrimination run a series of risks of varying importance including:

- production deadline overruns;
- interruption in manufacturing, entailing:
 - production or finished-product losses,
 - risk of damage to production machines in continuous processes;
- restarting of machines, one by one, following a general power outage;
- shutdown of vital safety equipment such as lubrication pumps, smoke fans, etc.

what is discrimination?

Discrimination, also called selectivity, is the coordination of automatic protection devices in such a manner that a fault appearing at a given point in a network is cleared by the protection device installed immediately upstream of the fault, and by that device alone.

■ total discrimination

Discrimination is said to be total if, for all fault current values, from overloads up to the non-resistive short-circuit current, circuit breaker D2 opens and D1 remains closed.

■ partial discrimination

Discrimination is partial if the above condition is not respected up to the full short-circuit current, but only to a lesser value termed the selectivity limit current (I_s).

■ no discrimination

In the event of a fault, both circuit breakers D1 and D2 open.

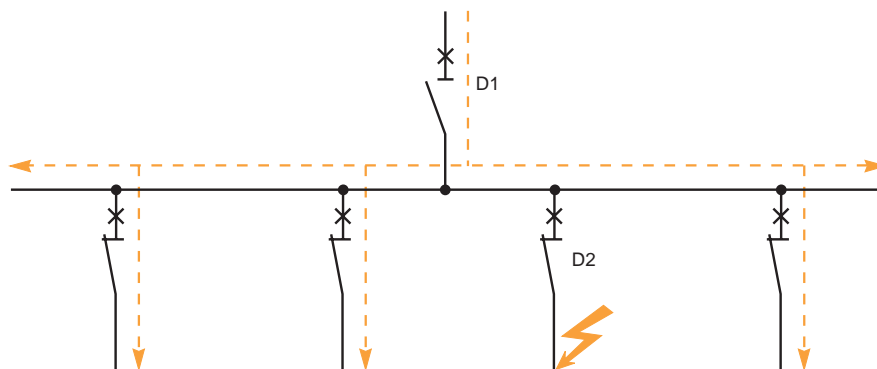

presentation

The table opposite lets you select the discrimination tables to be considered according to the upstream and downstream devices.

page	upstream device	downstream device
18	NC100 L, LH	C60H, C120H
10	C120H	C60H
-	Compact NS	C60H; C120N, H ; NC100L, LH

conditions for using discrimination tables between 2 distribution circuit-breakers

For each combination of two circuit-breakers, the discrimination tables indicate whether discrimination is total (coloured area).
When discrimination is partial, the table indicates the maximum value of the fault current for which discrimination is ensured. For fault currents in excess of this value, both devices trip at the same time.

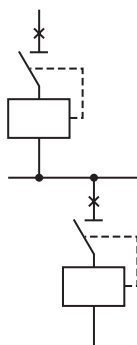

downstream circuit-breaker

The values indicated in the tables are guaranteed irrespective of the settings.

upstream circuit-breaker

The values indicated in the tables are guaranteed provided that the following conditions are met:

- thermal magnetic trip units: highest thermal and magnetic settings
- STR22SE/STR23SE electronic trip units: short delay settings ≥ 1.5 times the downstream short-circuit protection setting (magnetic or instantaneous)
- STR53UE electronic trip units:
 - short delay setting ≥ 1.5 times the downstream short-circuit protection setting,
 - time delay index > downstream trip unit time delay index

conditions for using discrimination tables between a circuit-breaker and a motor protection and control assembly

When discrimination is partial, the table indicates the maximum value of the fault current for which discrimination is ensured. For fault currents in excess of this value, both devices trip at the same time

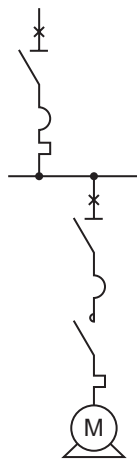

downstream device

The values indicated in the tables are guaranteed irrespective of the settings.

upstream device

The tables give the discrimination limits for the various trip unit ratings.

The values indicated in the tables are guaranteed provided that the following conditions are met:

- thermal magnetic trip units: highest magnetic setting, highest thermal setting, ≥ 3 times the rating of the downstream trip unit or thermal relay
- STR22SE/STR23SE and STR53UE electronic trip units:
 - short delay setting ≥ 1.5 times the downstream short-circuit protection setting (magnetic or instantaneous)
 - short time delay index (if STR53UE) > downstream device time delay index
 - long delay setting ≥ 3 times the rating of the downstream trip unit or thermal relay.

discrimination (short-circuit under 230 V)

upstream: C120 N, H, C curve

downstream: C60H

upstream		C120 H C curve										
In (A)		10	16	20	25	32	40	50	63	80	100	125
downstream	rating											
discrimination limit (A)												
C60 H	1	800	1000	2000	3000	4500	5500	7000	10000	10000	10000	10000
B, C curves	2	400	600	1000	2000	3000	3500	4000	6000	10000	10000	10000
	3	200	400	400	1300	2100	2300	2500	6000	10000	10000	10000
	4		200	300	900	1600	1800	2000	5000	8000	10000	10000
	6			200	500	1300	1400	1500	4000	6500	8500	10000
	10				300	800	900	1000	3500	6000	6500	8000
	16					500	650	800	3000	5000	6000	7000
	20						400	700	2000	3600	5500	6000
	25							500	1000	2200	3500	5000
	32								700	1500	2500	4000
	40									1300	1800	3600
	50										1500	2500
	63											2100
discrimination limit (A)												
C60 H	1	800	1000	2000	3000	4500	5500	7000	10000	10000	10000	10000
D curve	2		600	1000	2000	3000	3500	4000	8000	10000	10000	10000
	3			400	1300	2100	2300	2500	7000	10000	10000	10000
	4				900	1600	1800	2000	5000	8000	10000	10000
	6					1300	1400	1500	4000	6500	8500	10000
	10						900	1000	3500	5500	6500	8000
	16							800	3000	5000	6000	7000
	20								2000	3600	5500	6000
	25									2200	3500	5000
	32										2500	4000
	40											3600
	50											
	63											

The above tables indicate the discrimination limits in the following cases:

- phase-to-neutral short-circuit on a 230 V single-phase distribution network, downstream of a 3 Ph + N or single-phase network.
- short-circuit between two phases on a three-phase distribution network with a nominal voltage of 230 V.

upstream		C120 N C curve										
In (A)		10	16	20	25	32	40	50	63	80	100	125
downstream	rating											
discrimination limit (A)												
C60 H	1	300	450	600	1000	1600	2000	2500	6000	6000	6000	6000
B, C curves	2	150	300	450	600	800	1300	2000	6000	6000	6000	6000
	3	80	200	300	450	600	1000	1600	5000	6000	6000	6000
	4		160	250	350	500	1000	1600	4000	5000	6000	6000
	6			170	300	400	800	1200	2500	4000	6000	6000
	10				210	270	500	800	1000	3200	5000	6000
	16					270	400	600	1000	1600	3600	5500
	20						340	500	800	1200	3000	4000
	25							420	600	1000	2500	3200
	32								530	1000	1600	2500
	40									680	1000	1600
	50										850	1300
	63											1200
discrimination limit (A)												
C60 H	1	300	450	600	1000	1600	2000	2500	6000	6000	6000	6000
D curve	2		300	450	600	800	1300	2000	6000	6000	6000	6000
	3			300	450	600	1000	1600	5000	6000	6000	6000
	4				350	500	1000	1600	4000	5000	6000	6000
	6					400	800	1200	2500	4000	6000	6000
	10						500	800	1000	3200	5000	6000
	16							600	1000	1600	3600	5500
	20								800	1200	3000	4000
	25									1000	2500	3200
	32										1600	2500
	40											1600
	50											
	63											

The above tables indicate the discrimination limits in the following cases:

- short-circuit between two phases on a three-phase 230/400 V distribution network.

practical advice

discrimination

upstream: **C120 N**, C curve

downstream: C60 and C120

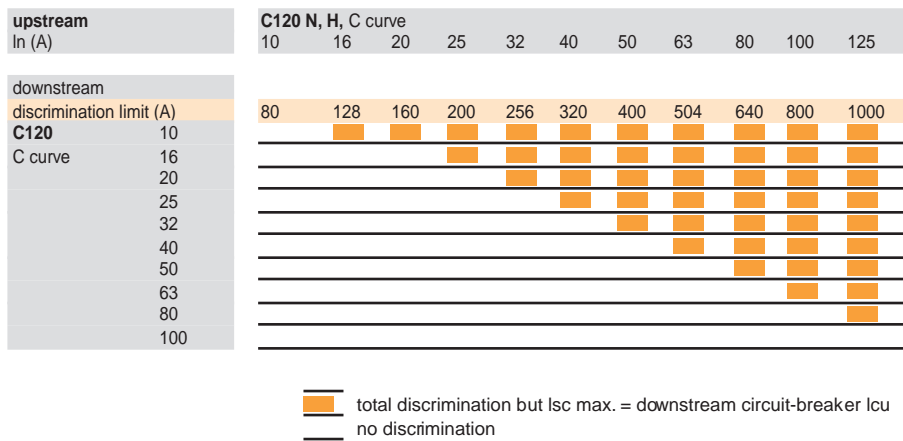
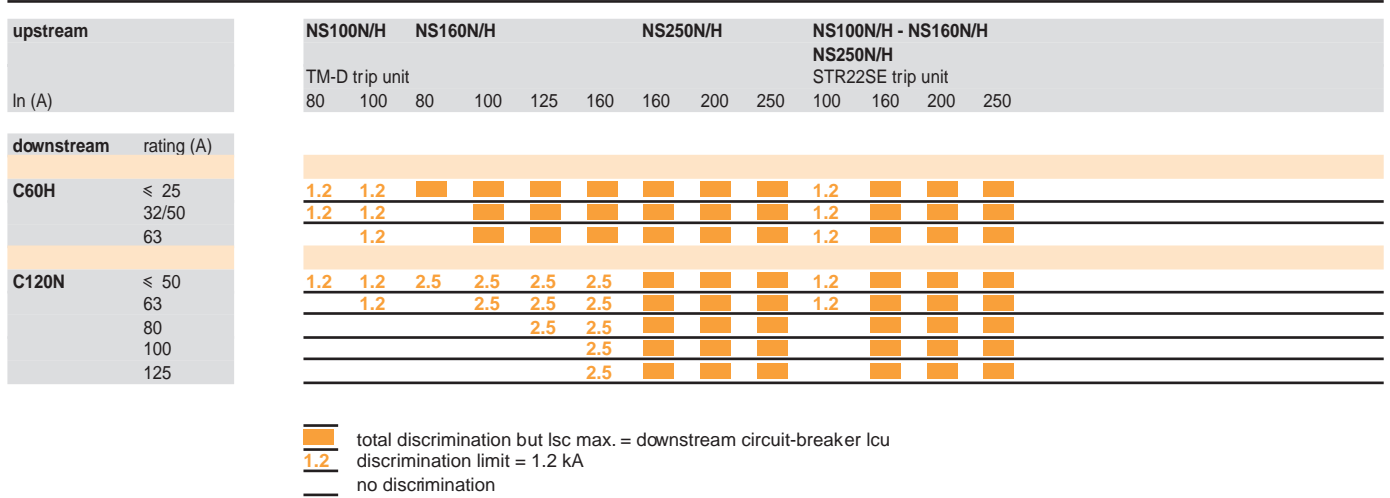

temperature derating multi 9

according to ambient temperature

residual current circuit-breakers

The thermal (overload) protection device placed upstream of the residual current circuit-breaker must take into account the values listed in the table below (IEC 61008).

temperature (°C)	25	30	40	50	60
rating (A)					
25	32	30	25	23	20
40	46	44	40	36	32
63	75	70	63	56	50
80	95	90	80	72	65
100	123	120	100	105	90
125	135	133	125	128	110

according to the installation mode

When several simultaneously operating circuit-breakers are mounted side by side in a small enclosure, the temperature rise inside the enclosure causes a reduction in current rating. You must then assign the rating (already derated if necessary according to ambient temperature) a downrating factor of 0.8.

according to ambient temperature

The maximum permissible current in a circuit-breaker depends on the ambient temperature where the circuit-breaker is placed.

Ambient temperature is the temperature inside the enclosure or switchboard in which the circuit-breakers are installed. The reference temperature is in the coloured column for the various circuit-breakers.

C60H

temperature (°C)	20	25	30	35	40	45	50	55	60
rating (A)									
1	1.05	1.02	1.00	0.98	0.95	0.93	0.90	0.88	0.85
2	2.08	2.04	2.00	1.96	1.92	1.88	1.84	1.80	1.74
3	3.18	30.9	3.00	2.91	2.82	2.70	2.61	2.49	2.37
4	4.24	4.12	4.00	3.88	3.76	3.64	3.52	3.36	3.24
6	6.24	6.12	6.00	5.88	5.76	5.64	5.52	5.40	5.30
10	10.6	10.3	10.0	9.70	9.30	9.00	8.60	8.20	7.80
16	16.8	16.5	16.0	15.5	15.2	14.7	14.2	13.8	13.3
20	21.0	20.6	20.0	19.4	19.0	18.4	17.8	17.4	16.8
25	26.2	25.7	25.0	24.2	23.7	23.0	22.2	21.5	20.7
32	33.5	32.9	32.0	31.4	30.4	29.8	28.4	28.2	27.5
40	42.0	41.2	40.0	38.8	38.0	36.8	35.6	34.4	33.2
50	52.5	51.5	50.0	48.5	47.4	45.5	44.0	42.5	40.5
63	66.2	64.9	63.0	61.1	58.0	56.7	54.2	51.7	49.2

C120

temperature (°C)	20	25	30	35	40	45	50	55	60
rating (A)									
10	11.4	11	10.7	10.4	10	9.4	9.2	8.8	8.4
16	18.2	17.6	17.1	16.6	16	15	14.7	14	13.4
20	22.7	22	21.3	20.7	20	18.7	18.3	17.5	16.7
25	29	28	27.1	26	25	23.8	22.7	21.2	20.2
32	37.1	35.8	34.7	33.3	32	30.5	29	27.1	25.8
40	46	44.5	43	41.5	40	38	36	34	32
50	57.6	55.7	53.9	51.9	50	47.8	45.7	43.3	41
63	73	70.5	68	65.5	63	60	57	54	51
80	91	88	85	82.5	80	77	74	60.5	57
100	114	11.5	107	103.5	100	96	92	87.5	83
125	144	139.5	135	130	125	118.5	114	108	102

power loss

circuit-breakers and switches

How much power is lost per pole?

The table below gives the power loss of the devices in Watts for each rating, per pole, for the rated current:

rating	1	2	3	4	6	10	16	20	25	32	40	50	63	80	100	125
circuit-breakers																
C60	2.3	2.5	2.4	2.4	3	2	2.6	2.7	2.9	3	3.5	4.6	4.5	6.6		
C120						1.7	2.3	2.65	2.7	3.8	3.6	4.5	4.8	4.5	6	8
NC100						1.2	2.0	2.2	2.6	3.3	3.8	4.4	6.5			
RCCB								1.3			3.2		3.2	6	9	
I switch							1.9		0.72		1.9		2.5			3.9

practical advice
use in 400 Hz
multi 9

The multi 9 and Compact circuit-breakers can be used on 400 Hz networks. Short-circuit currents at the terminals of the 400 Hz generators do not normally exceed 4 times nominal current. Consequently there are seldom any breaking capacity problems.

Multi 9 circuit-breakers

- no thermal derating

■ increase in magnetic thresholds:

- factor of 1.5 for DPN, DPN N and DPNa
- factor of 1.48 for C60
- factor of 1.40 for NC100
- factor of 4 for C120, use a B curve C120
- the residual current devices in the Multi 9 range can be used on 400 Hz networks. Note that the mA threshold varies according to network frequency (see curves below).

RCCB

variation curves of the operating residual current

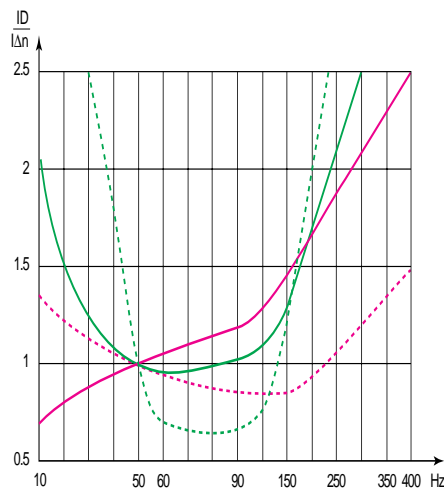

class	rating (A)	curve number				
		10	30	100	300	
RCCB						
AC	25	2	1	-	1	-
	25-40	-	1	1	1	-
	63-80-100	-	2	1	1	-
A	16-25-40-63	-	3	-	2	2

all types

SI	-	-	-	2	-	-
----	---	---	---	---	---	---

si RCCB

	-	4	-	-	-	-
--	---	---	---	---	---	---

C60 Vigi

variation curves of the operating residual current

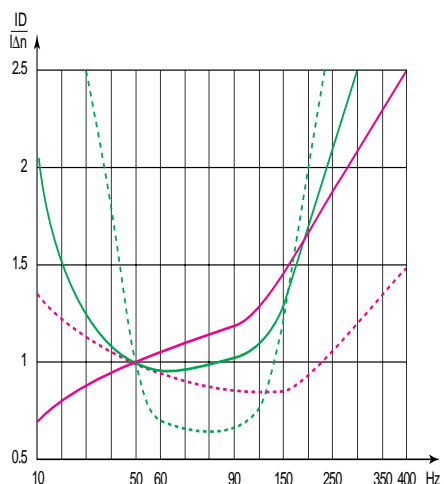

class	rating (A)	curve number				
		10	30	100	300	
110/220 V - 50 Hz C60 Vigi						
AC	25	2	1	1	-	-
	63	-	2	1	-	-

2, 3 and 4P 220/415 V - 50 Hz C60 Vigi

AC	25	2	1	1	-	-
	40-63	-	2	1	-	-
	A	25-63	3	3	2	2

all types

SI	-	4	2	2	-	-
----	---	---	---	---	---	---

si C60 Vigi

	4					
--	---	--	--	--	--	--

Remark:

In 400 Hz, threshold variation means there is a risk of the residual current device test circuit failing to operate when the test button is pressed.

According to international publications (IEC 60479-2), the human body is less

sensitive to current flow at 400 Hz, so that, despite frequency desensitisation of residual current devices, the latter continue to provide protection of persons. The method for choosing residual current devices in 400 Hz is thus the same as in 50 Hz.

CT contactor

use of multi 9 contactors from 16 to 100 A

For automation needs in the housing, tertiary and industrial sectors, the range of modular CT contactors is used for:

- power control of final circuits for housing and the tertiary sector
- lighting (luminous signs, shop windows, safety lighting, etc.)
- heating, heat pumps, ovens
- hot water for domestic use

- small utility motors (pumps, fans, barriers, garage doors, etc.)
- emergency stops and safety systems
- air conditioning
- energy distribution control:
 - load shedding and restoration
 - source changeover, etc.

characterisation on load types

Standard IEC 1095 applies to electromechanical contactors for domestic and similar purposes. It differs from standard IEC 947-4 (designed for industrial applications) by specific requirements relating to safety of persons and equipment in premises and corridors accessible to the general public.

applications	industrial: IEC 947.4	domestic: IEC 1095
motor	AC3	AC7b
heating	AC1	AC7a
lighting	AC5a and b	AC5a and b

use for temperatures between 50 and 60 °C

When contactors are mounted in enclosures with an internal temperature of between 50 and 60° C, a spacer, catalogue number 27062, must be placed between each contactor.

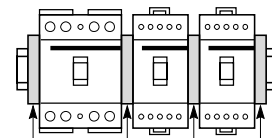

spacer catalogue number 27062

positioning the remote control contactors

This table positions each device according to:

- the number of cycles (total or daily)
 - the power to be controlled
- It provides information on the protection circuit-breaker to be associated.

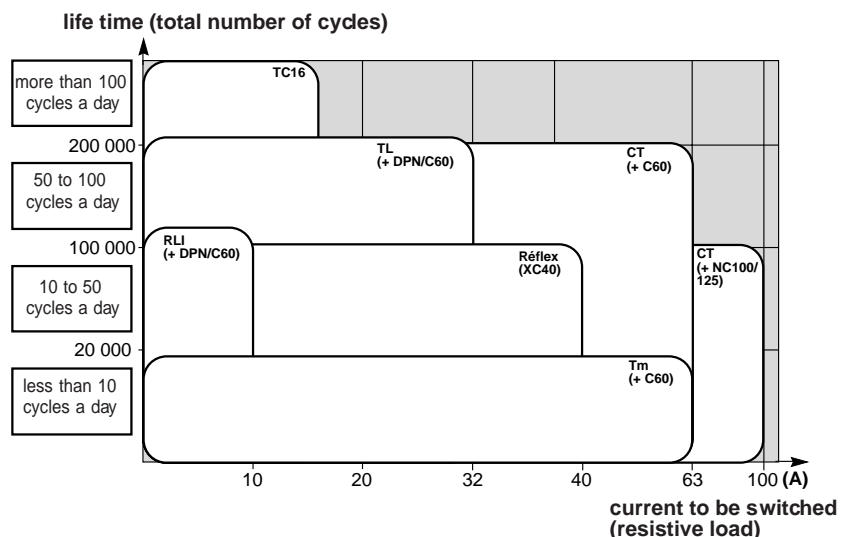

lighting application AC5a and AC5b categories

■ the following tables concern all the contactors from the CT range, with or without manual control, for 230 V single-phase lighting circuits
 ■ they indicate the contactor rating to be chosen according to the number and type of lamps to be controlled. As a guideline, maximum power is also given.

type of lighting application	maximum number of lamps for a given rating
230 V single-phase circuit	CT contactors
power (W)	16 A 25 A 40 A 63 A 100 A

incandescent lamp with or without halogen gas

40	38	57	115	172	250
60	30	45	85	125	187
75	25	38	70	100	150
100	19	28	50	73	110
150	12	18	35	50	75
200	10	14	26	37	55
300	7	10	18	25	37
500	4	6	10	15	22
1000	2	3	6	8	12

12 V halogen lamp (on ELV electromagnetic transformer)

20	15	23	42	63	94
50	10	15	27	42	63
75	8	12	23	35	52
100	6	9	18	27	40
150	4	6	13	19	28

26 mm fluorescent tube (single parallel-corrected)

15	15	20	40	60	90
18	15	20	40	60	90
20	15	20	40	60	90
36	15	20	40	60	90
40	15	20	40	60	90
58	10	15	30	43	64
65	10	15	30	43	64
115	5	7	14	20	30
140	5	7	14	20	30

26 mm fluorescent tube (single uncorrected)

15	22	30	70	100	150
18	22	30	70	100	150
20	22	30	70	100	150
36	20	28	60	90	135
40	20	28	60	90	135
58	13	17	35	56	84
65	13	17	35	56	84
115	7	10	20	32	48
140	7	10	20	32	48

26 mm fluorescent tube (dual serial-corrected)

2 x 18	30	46	80	123	180
2 x 20	30	46	80	123	180
2 x 36	17	25	43	67	100
2 x 40	17	25	43	67	100
2 x 58	10	16	27	42	63
2 x 65	10	16	27	42	63
2 x 118	6	10	16	25	37
2 x 140	6	10	16	25	37

■ to obtain an equivalence on:

- three-phase + neutral circuits: multiply the number of lamps and the power indicated in the table by 3.
- three-phase without neutral circuits: multiply the number of lamps and the power indicated in the table by 1.7.

type of lighting application	maximum number of lamps for a given rating
230 V single-phase circuit	CT contactors
power (W)	16 A 25 A 40 A 63 A 100 A

26 mm fluorescent tube (4 tubes, serial correction)

4 x 18	15	23	46	69	100
--------	----	----	----	----	-----

electronic ballast (1 x 26 mm tube)

18	74	111	222	333	500
36	38	58	117	176	260
58	25	37	74	111	160

electronic ballast (2 x 26 mm tubes)

2 x 18	36	55	111	166	250
2 x 36	20	30	60	90	135
2 x 58	12	19	38	57	85

electronic compact lamp (low consumption)

7	133	200	400	600	900
11	80	120	240	360	540
15	58	88	176	264	396
20	44	66	132	200	300
23	38	57	114	171	256

low pressure sodium vapour lamp (without correction)

18	18	34	57	91
35	4	9	14	24
55	5	9	14	24
90	3	6	9	19
135	2	4	6	10
180	2	4	6	10

low pressure sodium vapour lamp (with parallel correction)

18	14	21	40	60
35	3	5	10	15
55	3	5	10	15
90	2	4	8	11
135	1	2	4	6
180	1	2	5	7

high pressure sodium vapour lamp (without correction)

70	8	12	20	32
150	4	7	13	18
250	2	4	8	11
400	1	3	5	8
1000	-	1	2	3

high pressure sodium vapour lamp (with parallel correction)

70	6	9	18	25
150	6	9	18	25
250	2	3	6	9
400	2	4	8	12
1000	1	2	4	6

heating application

AC7a and AC1 categories

■ the following table concerns all the contactors in the CT range, with or without manual control, for 230 V single-phase and 400 V three-phase heating circuits.
 ■ it indicates the contactor rating to be chosen according to the power to be controlled and the number of operations a day.

type of heating application	maximum power (kW) for a given rating
number of operations / day	CT contactors
	25 A 40 A 63 A 100 A

230 V heating

25	5.4	8.6	14	21.6
50	5.4	8.6	14	21.6
75	4.6	7.4	12	18
100	4	6	9.5	14
250	2.5	3.8	6	9
500	1.7	2.7	4.5	6.8

400 V heating

25	16	26	41	63
50	16	26	41	63
75	14	22	35	52
100	11	17	26	40
250	5	8	13	19
500	3.5	6	9	14

small motor application

AC7b category

■ the following table concerns all the contactors in the CT range, with or without manual control, for 230 V single-phase and 400 V three-phase circuits.
 ■ it indicates the contactor rating to be chosen according to the power of the motor to be controlled.

small motor application type	maximum power (kW) for a given rating
voltage	CT contactors
	25 A 40 A 63 A

single-phase motor with capacitor

230 V	1.4	2.5	4
-------	-----	-----	---

three-phase motor

400 V	4	7.5	15
-------	---	-----	----

impulse relays

operating advice

Impulse relays are used to control circuits composed of resistive loads (incandescent lamps, low voltage halogen lamps, convectors) or inductive loads (fluorescent tubes, discharge lamps):

- the table opposite gives the power or maximum number of lamps which can be installed on a 230 V single-phase circuit
- for 230/400 V three-phase + neutral circuits, multiply these values by 3
- for 230 V three-phase circuits without neutral, multiply these values by 1.7.

lighting: maximum number of lamps on a 230 V single-phase circuit

maximum number of lamps on a 230 V single-phase circuit		max. power (W)	
		TL 16 A	TL 32 A
incandescent lamps			
tungsten filaments (230 V)	power (W)		
	40 60 75 100 200		
maximum no.	40 25 20 16 8	1600	
maximum no.	106 66 53 42 21		4260
halogen lamps (230 V)			
	300 500 1000 1500		
maximum no.	5 3 1 1	1500	
maximum no.	13 8 4 2		4000
ELV halogen lamps (12 or 24 V with transfo)			
	20 50 75 100		
maximum no.	70 28 19 14	1400	
maximum no.	180 74 50 37		3700

fluorescent tubes

single with starter (not corrected)					
	18 36 58				
maximum no.	70 35 21			1300	
maximum no.	186 93 55				3400
single with starter (parallel corrected)					
	18 36 58				
maximum no.	50 25 16			930	
maximum no.	133 66 42				2400
double with starter (series corrected)					
	2x18 2x36 2x58				
maximum no.	56 28 17			2000	
maximum no.	148 74 45				5300
HF single tubes and ballast					
	16 32 50				
maximum no.	80 40 26			1300	
maximum no.	212 106 69				3400
HF double tubes and ballast					
	2x16 2x32 2x50				
maximum no.	40 20 13			1300	
maximum no.	106 53 34				3400

discharge lamps

low pressure					
sodium vapour	55 90 135 180				
maximum no.	24 15 10 7			1300	
maximum no.	63 40 26 18				3400
high pressure sodium vapour or metallic iodides					
	250 400 1000				
maximum no.	5 3 1			1300	
maximum no.	13 8 3				3400

heating: maximum power on a 230 V (W) single-phase circuit

maximum power (W) on a 230 V single-phase circuit		max. power (W)	
		TL 16 A	TL 32 A
heating (AC1)		3600	7200

mechanical and electrical link

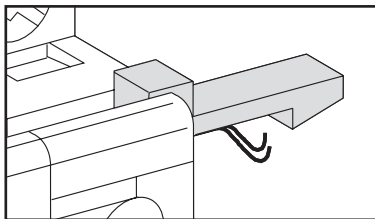

The 2 ETL extensions and the ATLt, ATLz, ATL4, ATLC+s auxiliaries can be clipped-on. The yellow clip ensures the mechanical link in all cases and, sometimes, the electrical link (see table opposite). The link is indicated by a dotted line on the add-on auxiliary electrical diagrams.

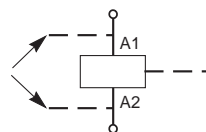

mechanical link	electrical link (terminals A1 and A2)
-----------------	---------------------------------------

extensions

ETL	■	■
-----	---	---

auxiliaries

ATLt	■	■
ATLz	■	■
ATL4	■	■ only terminal A1 with the left impulse relay
ATLC+s	■	■ only terminal A1
ATLC+c	cannot be clipped on	

circuit-breaker selection for DC applications

applications

type of system	earthed systems one polarity of the DC supply is earthed	a centre point of the DC supply is earthed	insulated systems
diagrams and various cases of faults			
fault effect	<p>fault A: max. I_{sc} the positive polarity is the only one involved</p> <p>fault B: max. I_{sc} both polarities are involved</p> <p>fault C: no effect</p>	<p>I_{sc} close to max. I_{sc} the positive polarity is the only one involved, voltage U/2</p> <p>max. I_{sc} both polarities are involved same as fault A but this is the negative polarity which is involved</p>	<p>no effect</p> <p>max. I_{sc} both polarities are involved no effect</p>
most unfavorable case	fault A	faults A and C	fault B
distribution of the breaking poles	the poles required to perform the break are in series on the positive polarity	on each polarity there must be the number of poles required to perform the break of max. I _{sc} at U/2	the poles required to perform the break are shared between the 2 polarities

Calculation the short-circuit current (I_{sc}) across the terminals of a battery

When a short-circuit occurs across its terminals, a battery discharges a current given by Ohm's law:

$$I_{sc} = \frac{V_b}{R_i}$$

where V_b = the maximum discharge voltage (battery 100 % charged), and R_i = the internal resistance equivalent to the sum of the cell resistances (figure generally given by the manufacturer according to the capacity of the battery).

Example

What is the short-circuit current at the terminals of a standing battery with the following characteristics:

- capacity: 500 Ah
 - max. discharge voltage: 240 V (110 cells of 2.2 V)
 - discharge current: 300 A
 - autonomy: 1/2 hour
 - internal resistance: 0.5 mΩ per cell.
- $$R_i = 110 \times 0.5 \cdot 10^{-3} = 55 \cdot 10^{-3}$$
- $$I_{sc} = \frac{240}{55 \cdot 10^{-3}} = 4.4 \text{ kA}$$

As the above calculation shows, the short-circuit current is relatively weak.

Note: if the internal resistance is not known, the following approximate formula can be used: I_{sc} = kC, where C is the capacity of the battery expressed in Ampere-hours, and k is a coefficient close to 10 but in any case always lower than 20.

- 240 V DC
- 300 A
- 500 Ah
- R_i = 0.5 mW/cell



Example 1

Determine the protection required for a 80 A feeder on a 125 V DC network with an earthed negative pole and an I_{sc} of 15 kA.

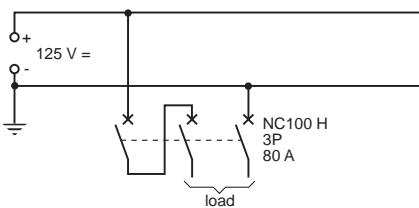

The table opposite indicates that a C120 circuit breaker (30 kA, 2P, 125 V) should be used.

The table above indicates that both circuit breaker poles should be fitted on the positive pole of the network.

An additional circuit breaker pole can be fitted on the negative pole of the network for isolation purposes.

Example 2

Determine the protection required for a 100 A feeder on a 250 V DC network with an earthed middle point and an I_{sc} of 15 kA.

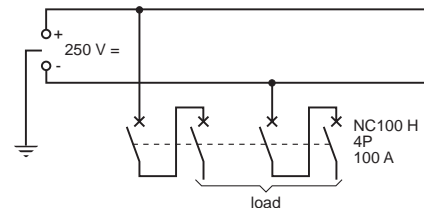

Each pole will be exposed to a maximum of U/2 = 125 V.

The table opposite indicates that C120 (30 kA, 2P, 125 V), NS100N (50 kA, 1P, 125 V) or NS160N (50 kA, 1P, 125 V) circuit breakers should be used.

The table above indicates that both circuit breaker poles must take part in the breaking at a voltage of 125 V.

Example 3

Determine the protection required for a 400 A feeder on an unearthed 250 V DC network with an I_{sc} of 35 kA.

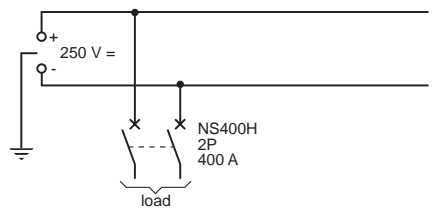

The table opposite indicates that NS400H circuit breakers (85 kA, 1P, 250 V) should be used. At least 2 poles must take part in breaking.

The table above indicates that half the number of circuit breaker poles required for breaking should be fitted on the positive pole of the network and the other half on the negative pole.

selection table of DC circuit breakers

In brackets, the number of poles involved in breaking

type of circuit breaker	rating	DC breaking capacity (kA)-L/R < 0.015 s				magnetic	up-rating coef.
		voltage ≤ 60 V	125 V	125 V	250 V		
C60H	1 to 63	20 (1 P)	25 (2P)	40 (3P)	50 (4P)	500 V	1.38
C120 N	63 to 125	15 (1 P)	15 (1 P)	25 (2 P)	40 (1 P)		
C120 H	10 to 125	25 (1 P)	25 (1 P)	30 (2 P)	50 (1 P)		
NC100LH	10 to 63	50 (1 P)	50 (1 P)		50 (1 P)	50 (3 P)	1.42

coordination

upstream: NC100 circuit-breaker or fuses

downstream: RCCB residual current circuit-breaker

residual current circuit-breaker

- One of the choice criteria for this device is coordination with the short-circuit protection device (SCPD) installed upstream.
- It must have the following protections:
 - **electrodynamic** against short-circuits developing downstream, as its short-circuit withstand is limited,
 - **overload** (see thermal protection)
- when combined with downstream circuit-breakers in the same switchboard produced using proper procedures, it is accepted that its short-circuit current withstand is also guaranteed by the downstream circuit-breakers as in the following table.

Example:

2P ID + downstream C60N combination
Isc withstand: 25 kA.

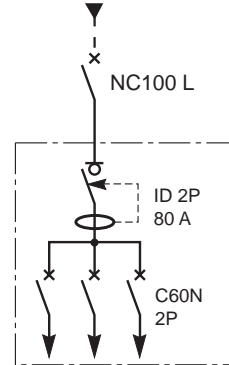

electrodynamic protection

short-circuit current (kA rms)

upstream	circuit-breaker				gl or gG fuse (a)								
	C60H	NC100L	NC100LH	C120	16	25	32	40	50	63	80	100	
downstream residual current circuit- breakers 2 P (220...240 V)	25 A	20	20	-	100	100	100	80	50	30	20	10	
	40 A	20	20	-	100	100	100	80	50	30	20	10	
	63 A	20	20	10	100	100	100	80	50	30	20	10	
	80/100 A	20	20	10	100	100	100	80	50	30	20	10	
4 P (380...415 V)	25 A	10	15	20	-	100	100	100	80	50	30	20	10
	40 A	10	15	20	-	100	100	100	80	50	30	20	10
	63 A	10	15	20	7	100	100	100	80	50	30	20	10
	80 A	10	15	20	5	100	100	100	80	50	30	20	10
	100 A	7	10	5	5	100	100	80	50	30	10	3	3

coordination

upstream: C60, NC100, NS100 or NS160

downstream: Multi 9 switches

short-circuit current withstand of the circuit-breaker / switch combination

standard: IEC 947.2

unit: kA

upstream	circuit-breaker		NC100 H
	C60 H	L	
downstream			
Multi 9 switch (240 V)			
I 20	6.5	6.5	3
I 32	5.5	5.5	3
I 40 - 63	7	7	5
I 100 - 125			7
Multi 9 switch (415 V)			
I 20	4.5	4.5	2
I 32	4	4	2
I 63	5	5	3
I 100			5

switch making capacity

use a circuit-breaker with a rating equal to that of the switch

unit: kA rms

upstream	circuit-breaker		NC100 H
	C60 H	L	
downstream			
Switch (240 V AC)			
≤ 40	63	84	42
50/63	63	63	42
100/125			42
Switch (415 V AC)			
≤ 40 A	32	42	21
50/63 A	32	32	21
100 A			21
125 A			

modular switchgear dimensions

protect

C60 circuit-breakers

circuit-breakers

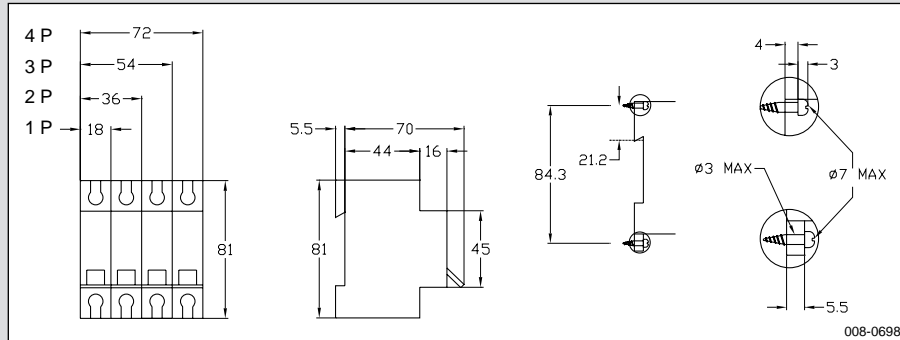

surface mounting

Vigi C60 (auxiliaries)

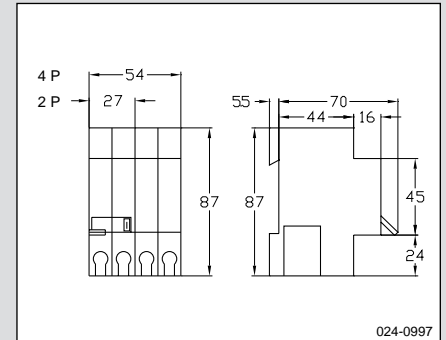

OF, SD, MX, MN (auxiliaries)

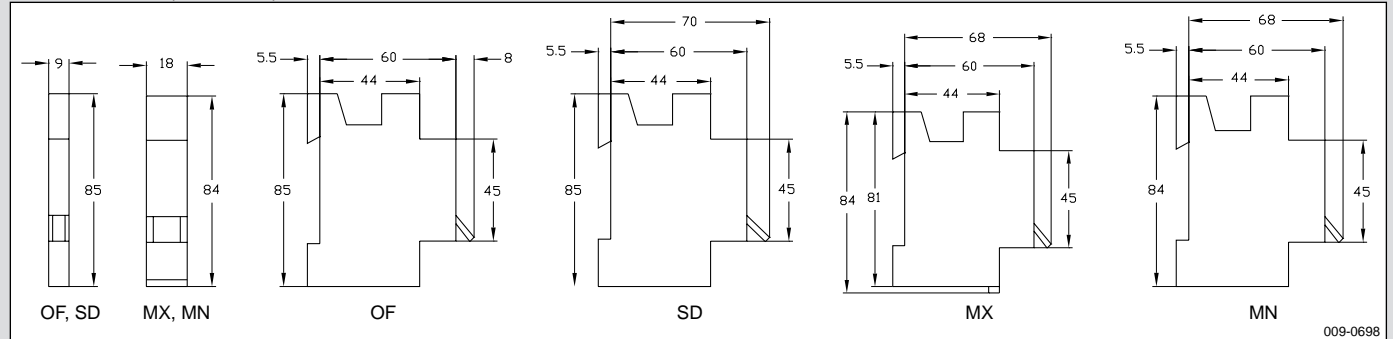

RCCB 10...300 mA residual current circuit-breakers

circuit-breakers

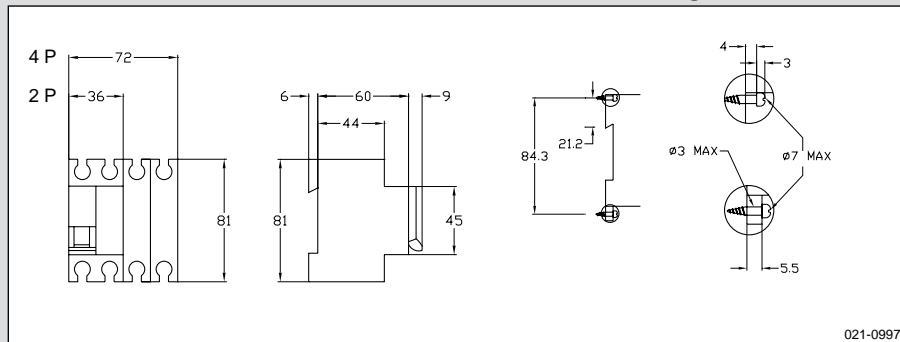

surface mounting

OF, MX, MN (auxiliaries)

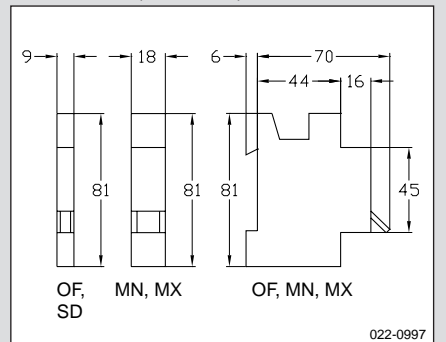

modular switchgear dimensions

control

Impulse relays

TL et ETL extension

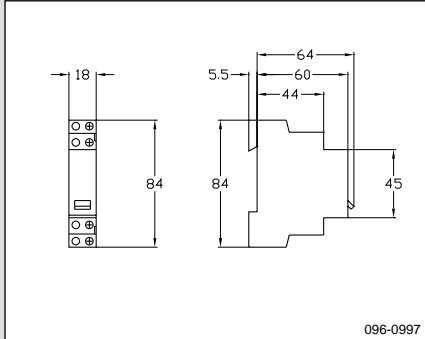

add-on auxiliaries
ATLc+s, ATLc+c, ATLz, ATL4

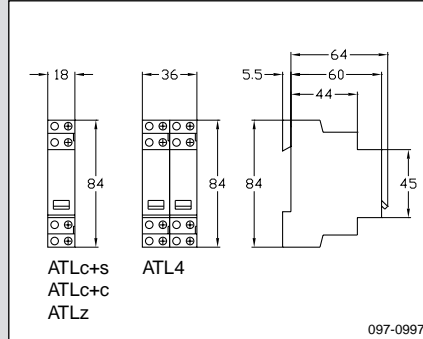

TLc, TLm and TLs impulse relays
with built-in auxiliary function

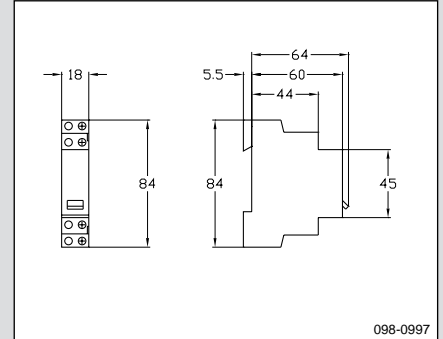

I switch-disconnectors

20 and 32 A

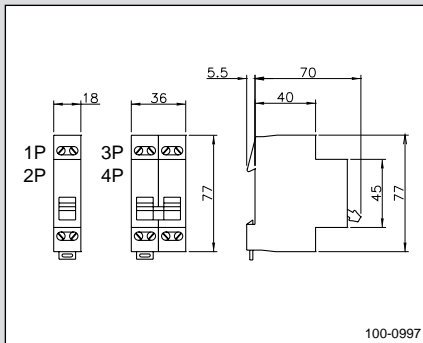

40 to 125 A

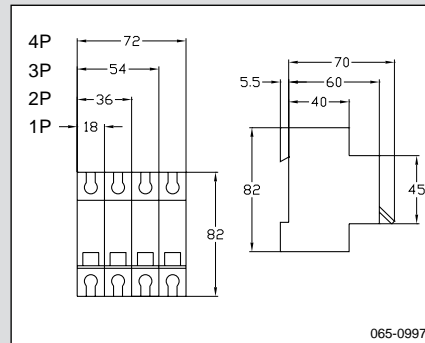

NO, NF (auxiliaries)

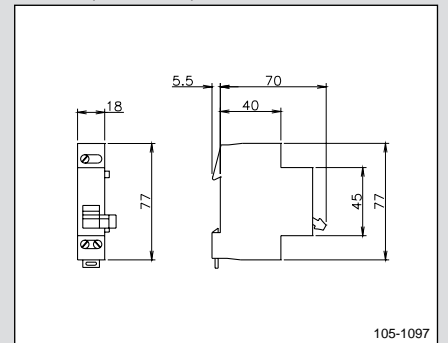

CM selector switches

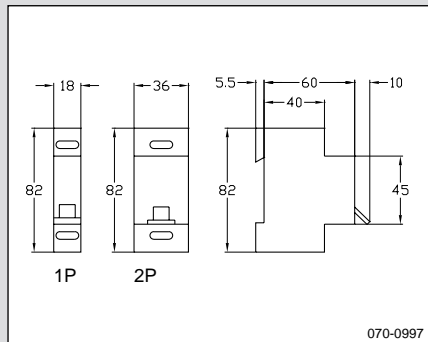

CT contactors

contactors 16/25 A

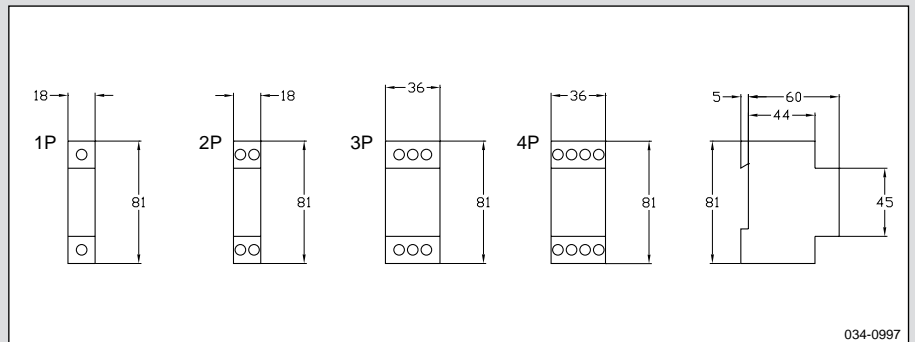

contactors 40/63 A

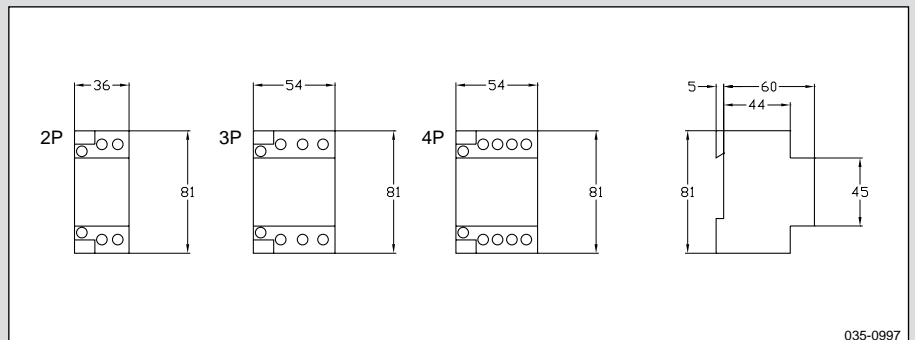

modular switchgear dimensions

manage

Time switches

IH time switches 2 modules

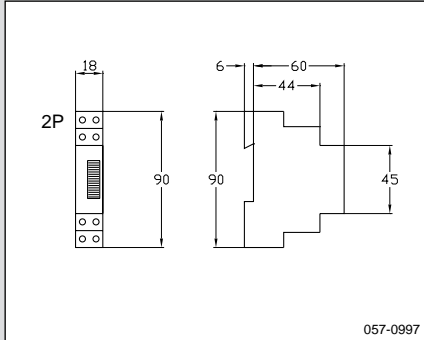

6 modules

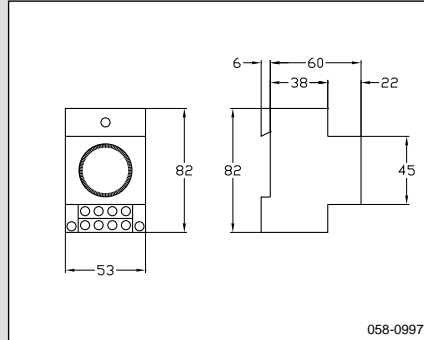

8 modules

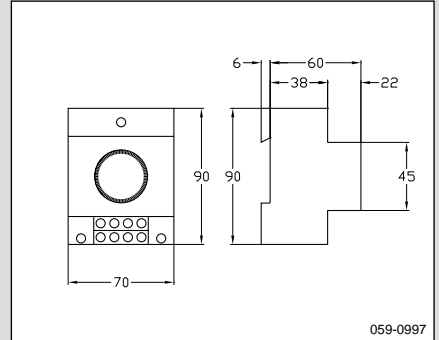

12 modules

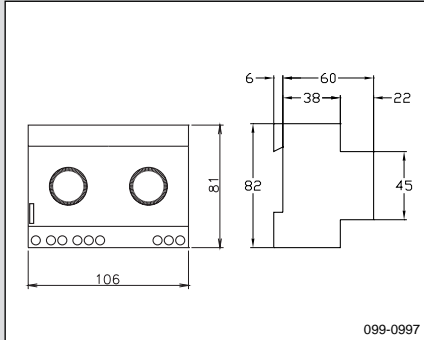

IHP programmable time switches IHP

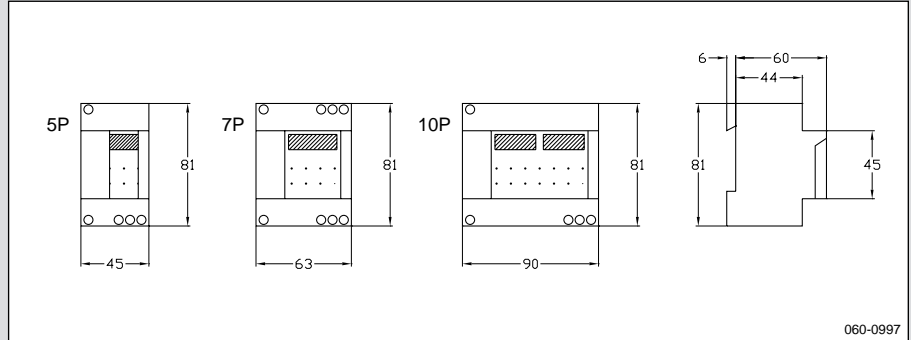

IC light sensitive switches

IC200, IC2000 and IC2000P

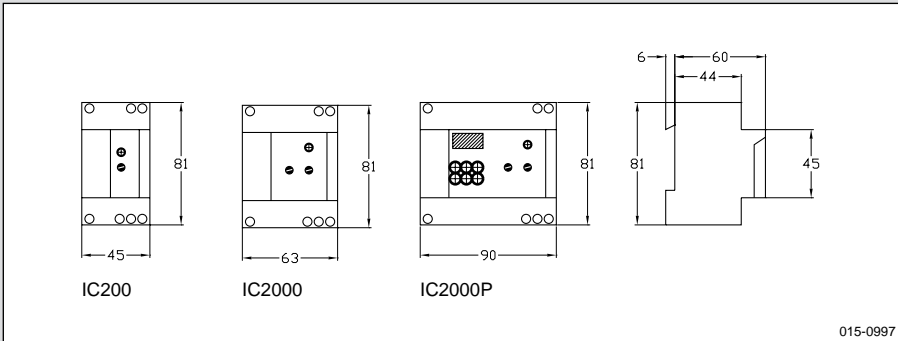

"front face" and wall-mounted cell

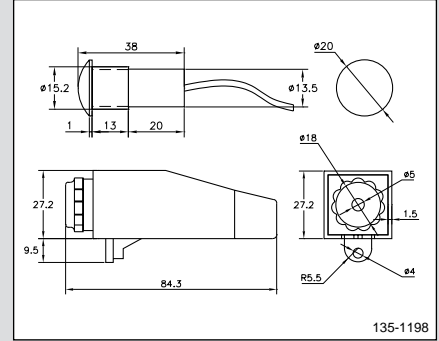

ICWo and ICWs

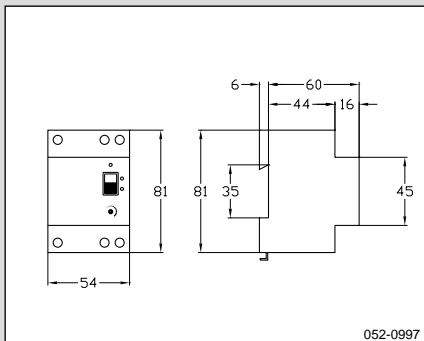

"front face" and wall-mounted cell

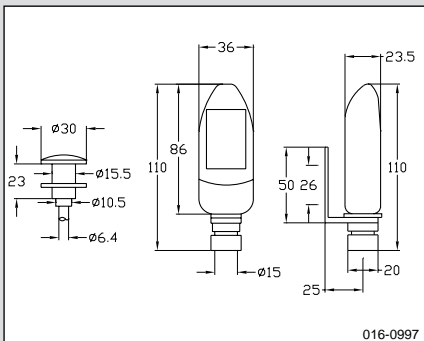

modular switchgear dimensions

monitor

V indicator lights

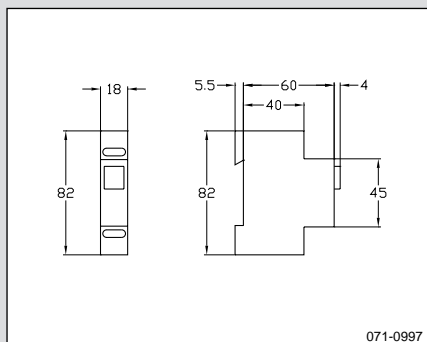

071-0997

Current transformers

catalogue numbers 16500 to 16506

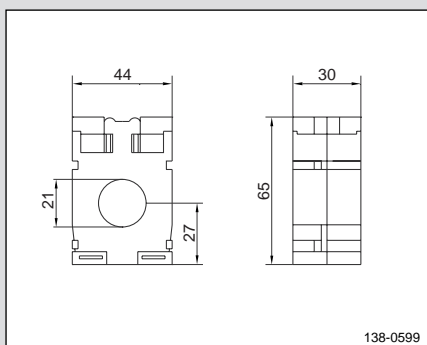

138-0599

Voltmeters, ammeters et selector switches

digital VLT and AMP

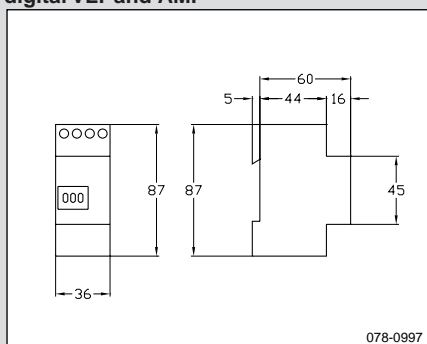

078-0997

VLT and AMP 72 x 72

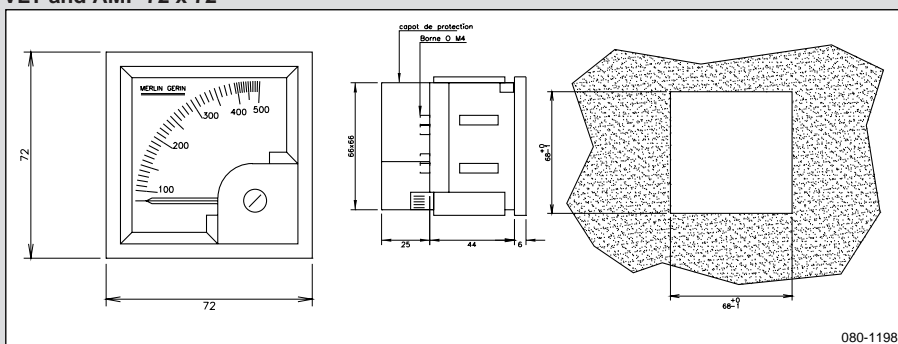

080-1198

CMA and CHV

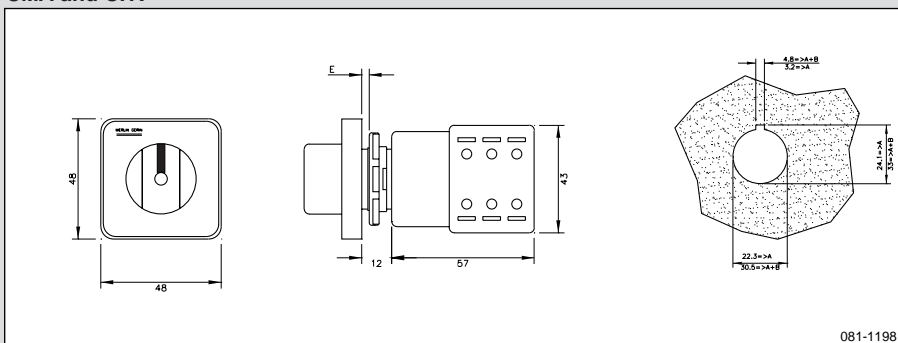

081-1198

modular enclosure dimensions

Flush mounting Mini Pragma

side view

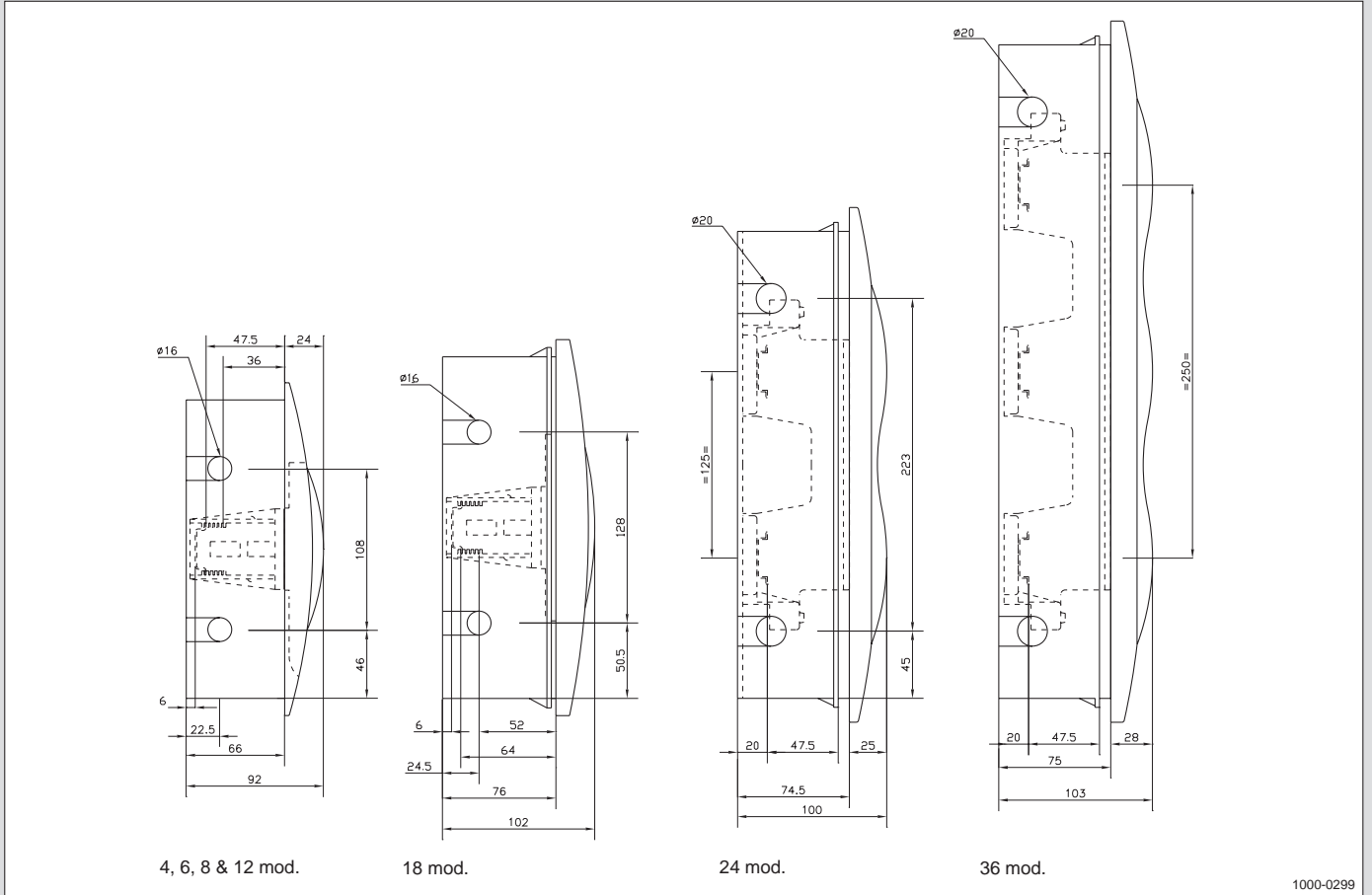

1000-0299

flush mounting

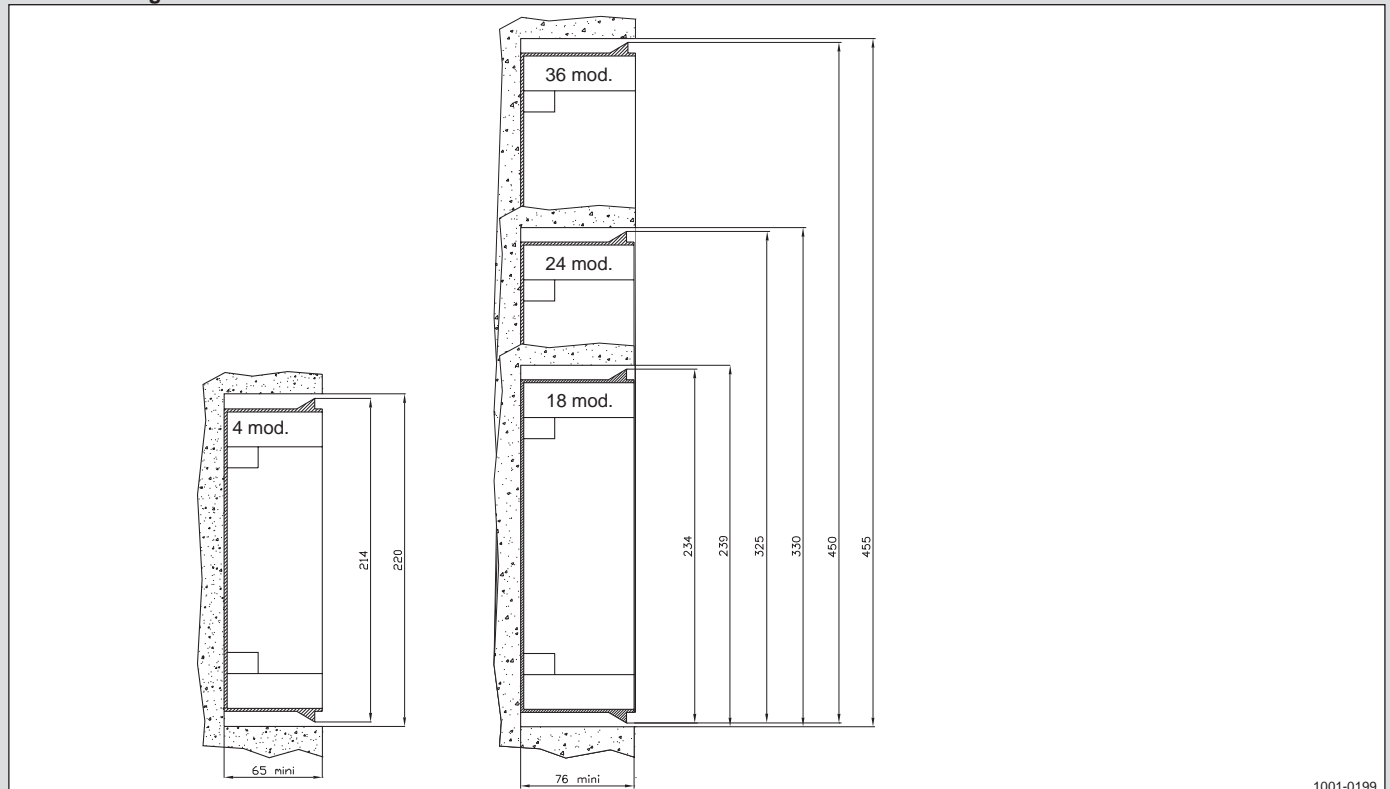

1001-0199

front view

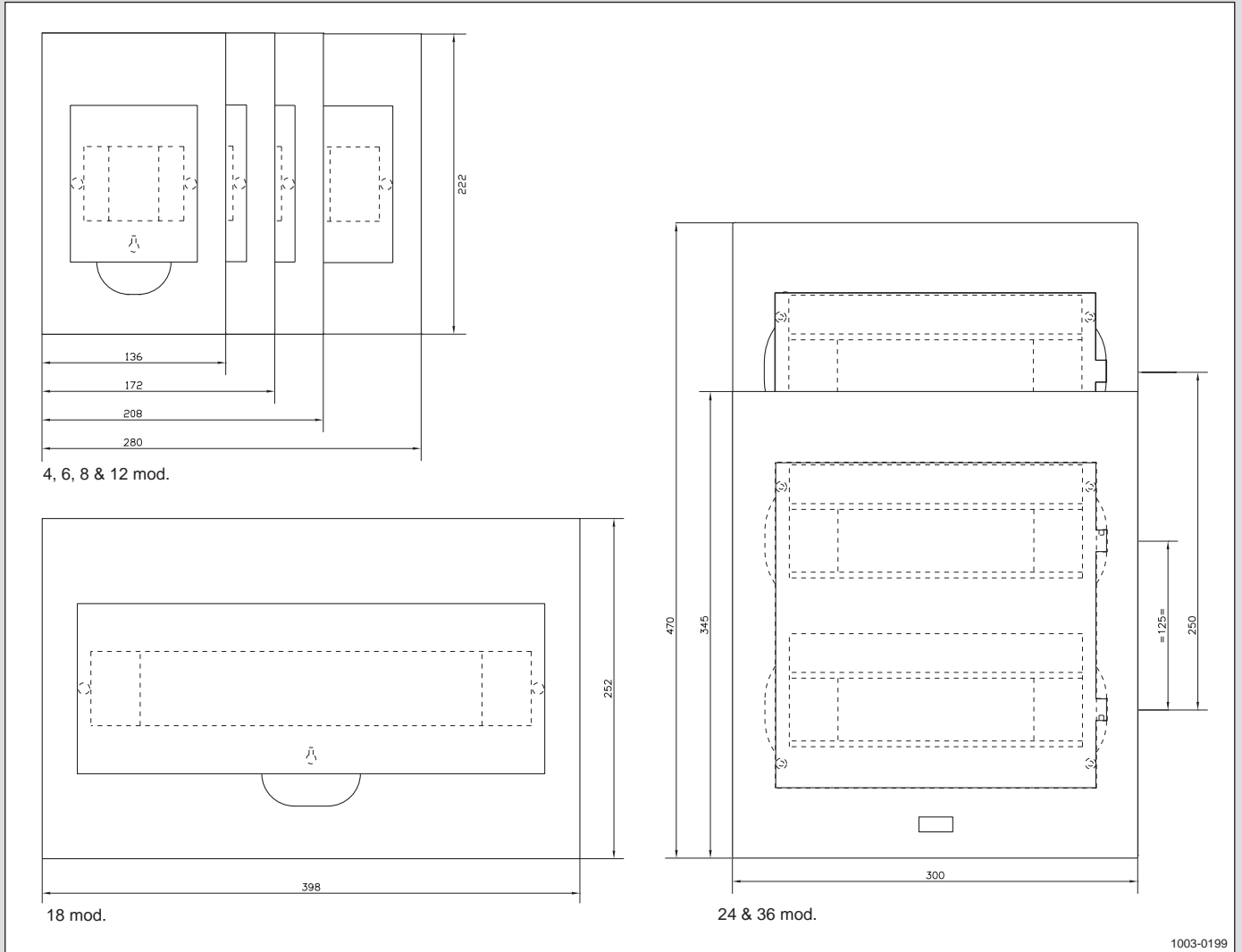

top view

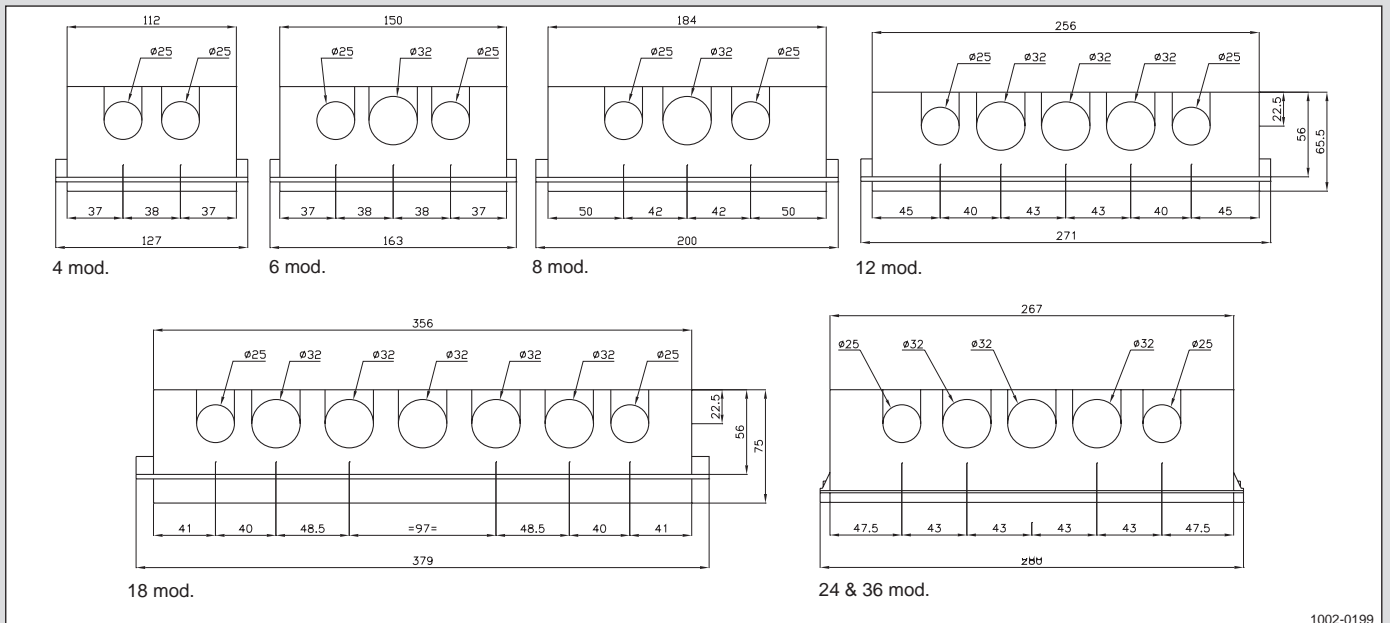

modular enclosure dimensions

Surface mounting Mini Pragma

side view

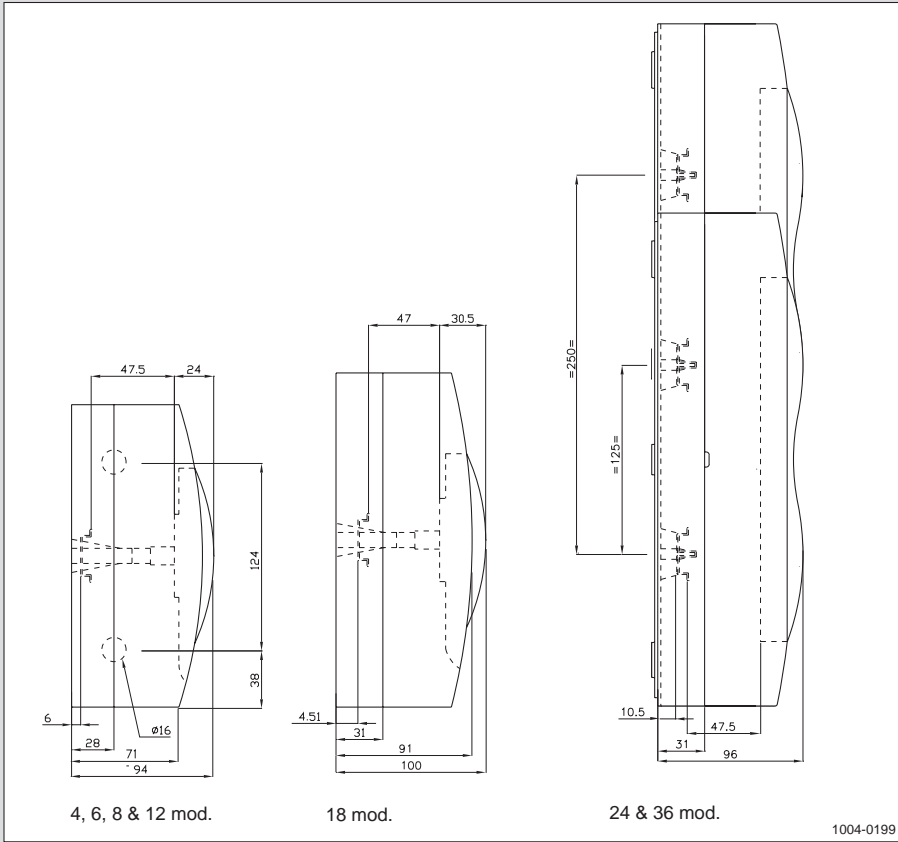

front view

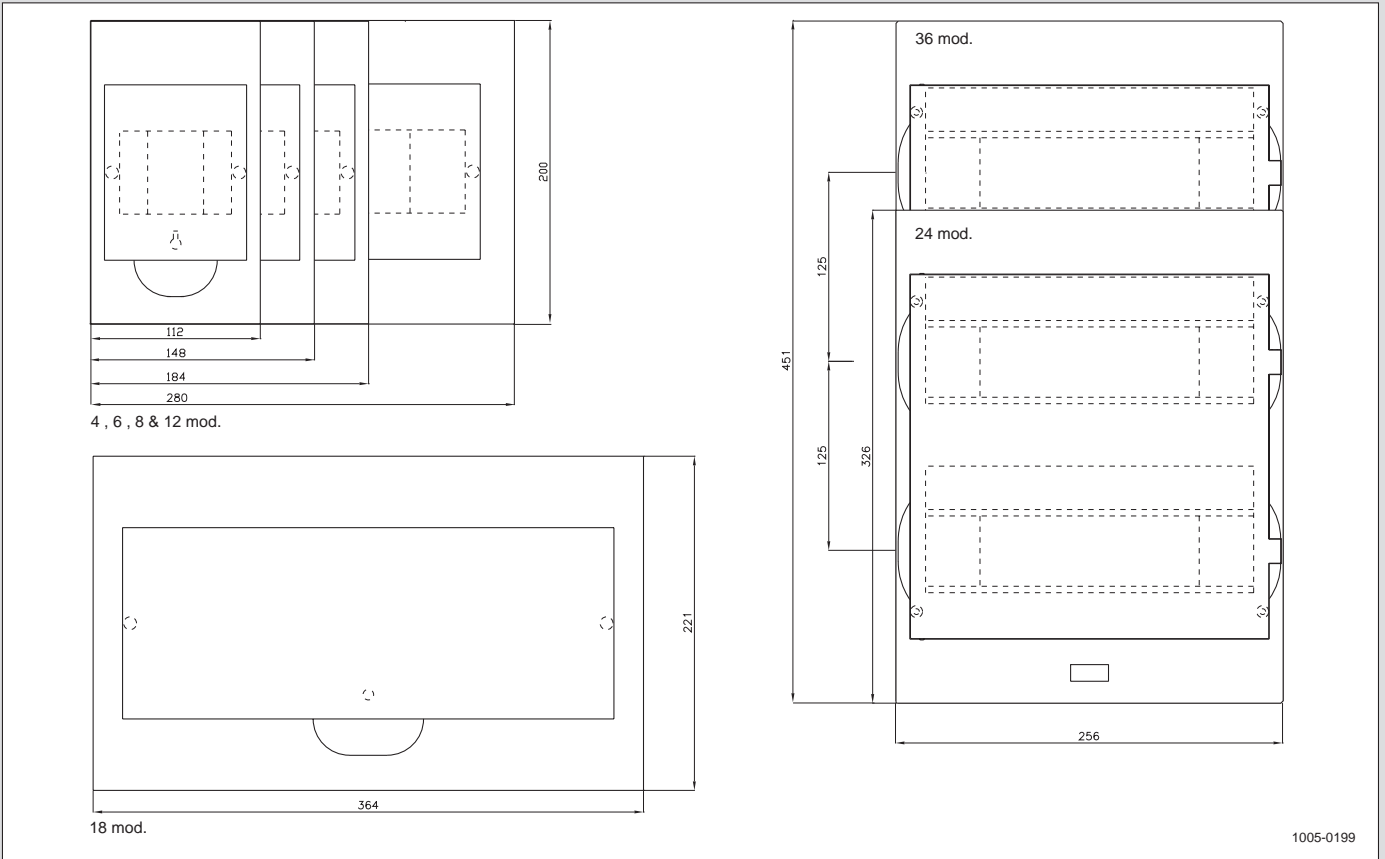

top view

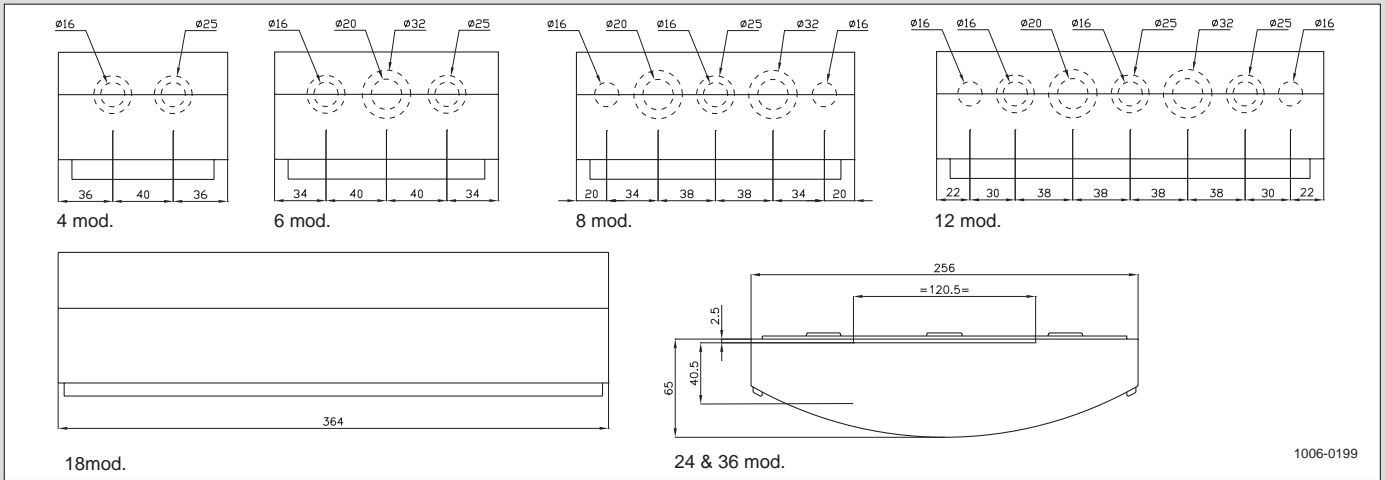

back view

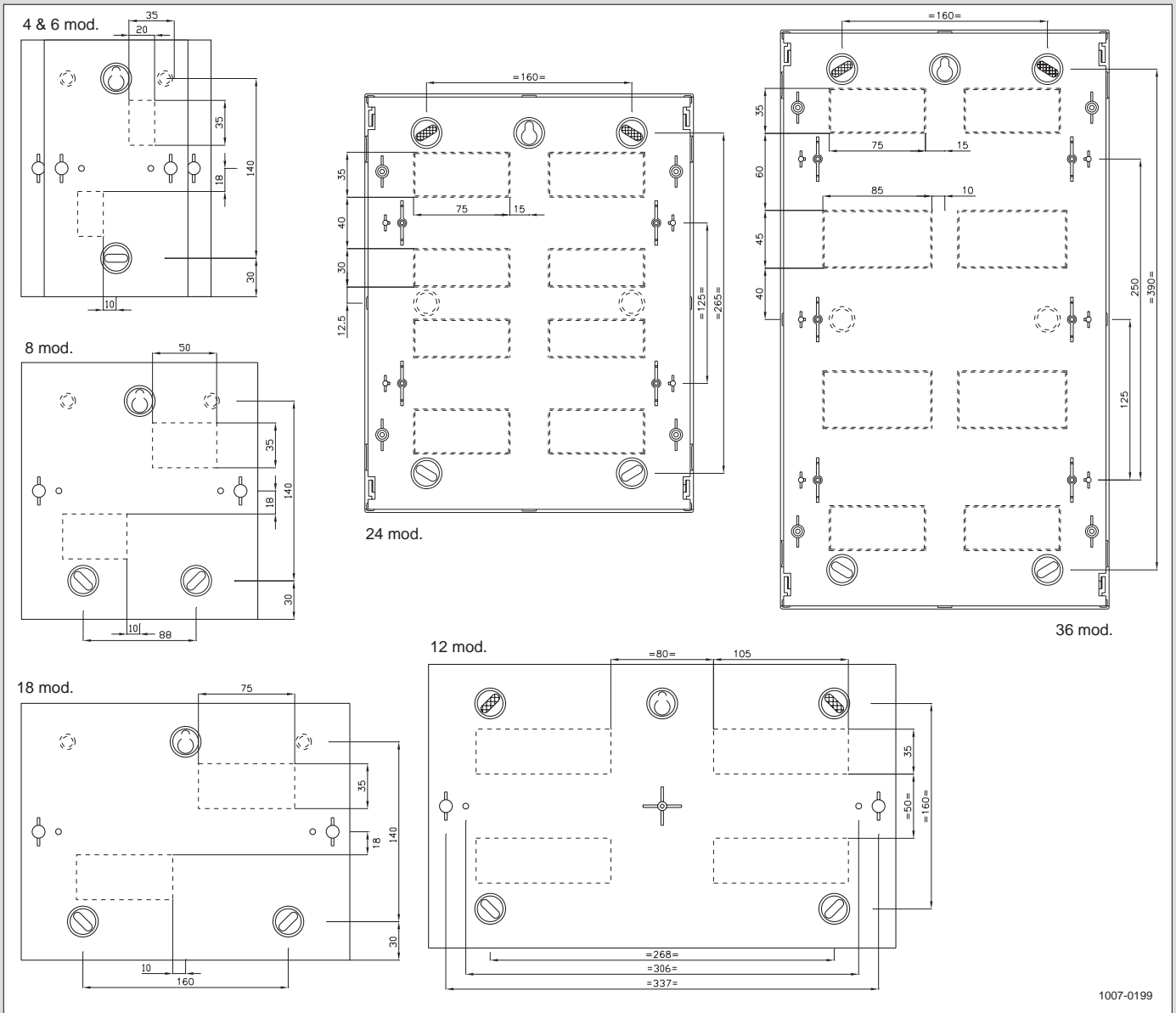

modular enclosure dimensions

Weatherproof Mini Pragma

front view

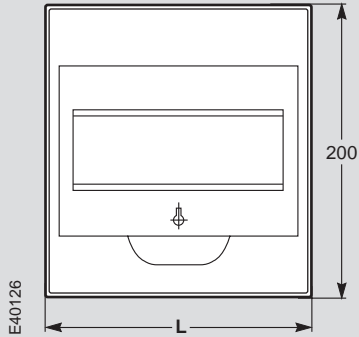

side view

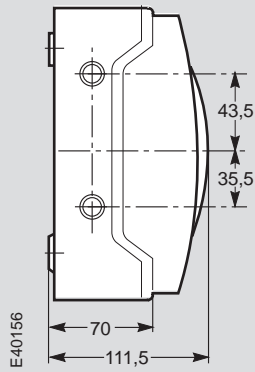

position of rail DIN

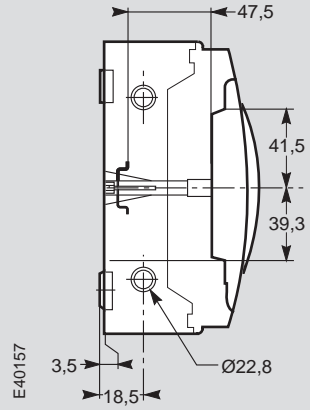

wall mounting

3, 4 and 6 modules 8 and 12 modules

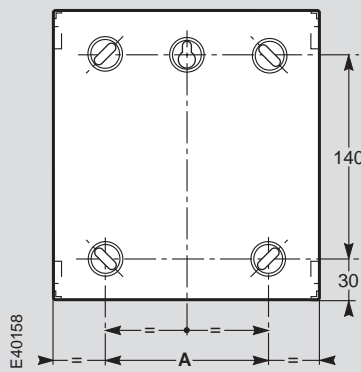
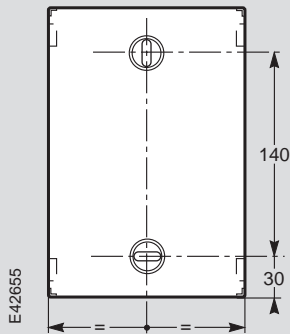

number of module	A	L
3	-	105
4	-	123
6	-	159
8	88	195
12	160	267

top view (offer F and offer B)

3 modules

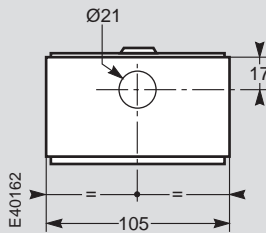

4 modules

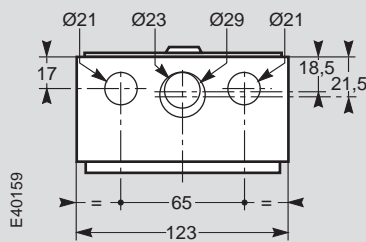

6 modules

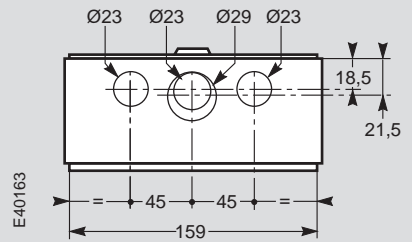

8 modules

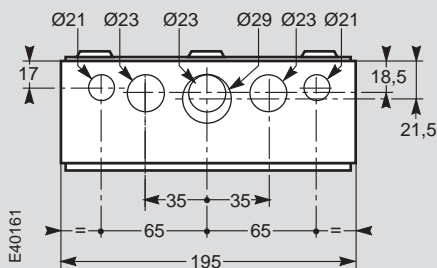

12 modules

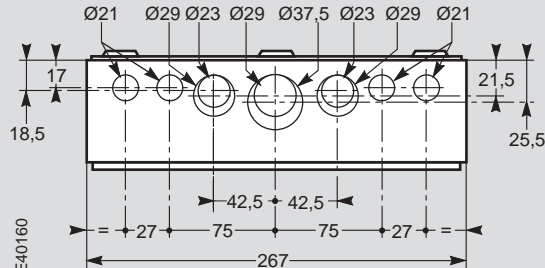

Sheet steel distribution boards

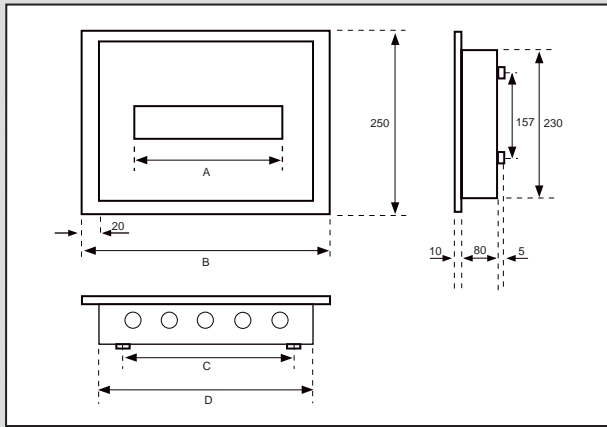

Single Phase Distribution Board*

Type	A	B	C	D
4W-2P	108	238	116	220
8W-2P	180	311	116	293
12W-2P	252	395	200	377

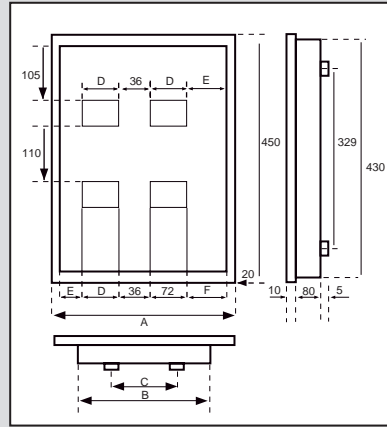

Three Phase Distribution Board

Type	A	B	C	D	E	F
4W-4P	392	372	292	108	50	86
8W-4P	566	546	466	180	65	105
12W-4P	710	690	610	252	65	245

Thermoplastic distribution boards

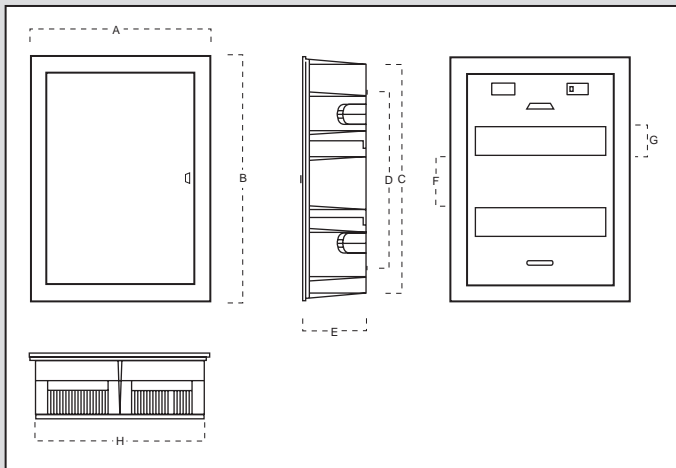

DB version	A	B	C	D	E	F	G	H
I TIER DB	300	278	255	155	86	NA	45	278
II TIER DB	300	403	380	280	86	80	45	278
III TIER DB	300	528	505	405	86	80	45	278

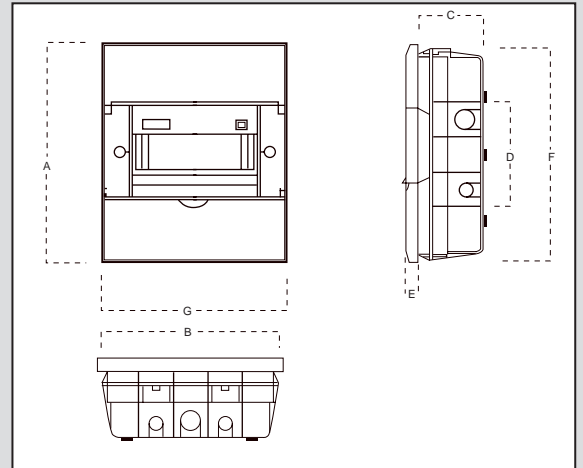

DB version	A	B	C	D	E	F	G
8 POLE DB	264	223	80	126	14	254	213

* development is a continuous process at Merlin Gerin
technical data is subject to change