

**Current Transformer operated**

- Three phase motor currents are monitored through three internal current transformers.

**Operating and Function**

- LR97D, solid state overload relay, compares motor current with preset load current threshold (LOAD).
- D-Time counts down and is only available for motor starting. During steady state, if motor current is greater than the current setting (overloaded), LR97D switches its contacts after O-Time. In case of phase failure and locked rotor trip delay time is 3 sec and 0.5 sec respectively. (Refer to "Easy troubleshooting" and "Time based Function")
- For shear-pin (mechanical shock) protection, Set O-Time knob to its minimum in order to trip in 0.2~0.3 sec.

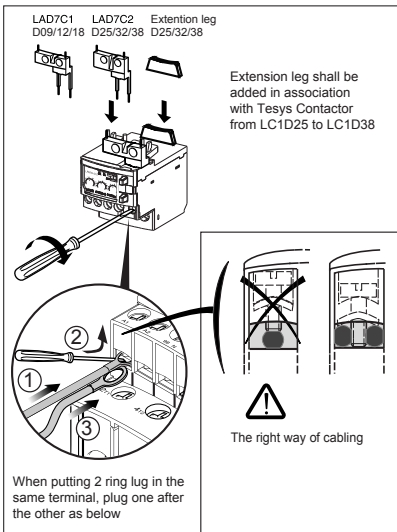
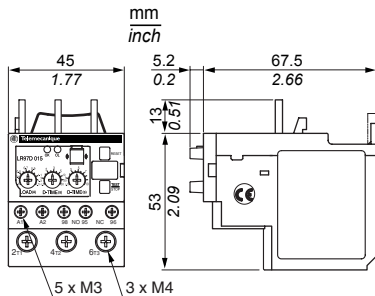

Protective Item	Operating Characteristics	Trip Delay Time
Overcurrent	$I_{max} > I_s$	O-Time
Phase Loss	$I_{min} < 10\% \text{ of } I_{max}$	< 3 sec
Locked Rotor	$I_{max} > 3 \times I_s$	Starting : D-Time Running : < 0,5 sec

$I_{max}$ : Maximum phase current  
 $I_{min}$ : Minimum phase current  
 $I_s$ : Overload setting current

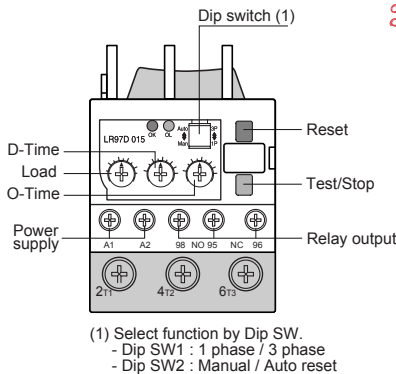

✂ Combined signals from red and green LEDs indicate motor status including trip causes.

Condition	LED Signal(Pulse Chart)	
	Green LED	Red LED
Power on	On [Pulse Chart]	Off [Pulse Chart]
Starting	[Pulse Chart]	[Pulse Chart]
Steady state	On [Pulse Chart]	Off [Pulse Chart]
Overloading	On [Pulse Chart]	[Pulse Chart]
Trip	Overcurrent Off [Pulse Chart]	On [Pulse Chart]
Locked rotor	Off [Pulse Chart]	[Pulse Chart]
Phase Loss	L1 Off [Pulse Chart]	[Pulse Chart]
	L2 Off [Pulse Chart]	[Pulse Chart]
	L3 Off [Pulse Chart]	[Pulse Chart]

→ Available for 3 phase utilisation only (Dip SW on "3P" position)

**Notes / Caution for safety**

- In case trip cause is unknown, please contact our company by e-mail or phone.
- Please read this manual and the following documents carefully, before setting, wiring, operating, repairing or checking. Use this product in a right way.
- This issue replaces all previous issues. Availability, errors and specifications subject to change without notice(warning).
- **Please keep this manual till the product is disused.**
- The notes for safety are indicated in letters such as Warning and Caution as following.

**WARNING !**

These safety instructions are intended for all work on the LR97D. Neglecting these instructions can cause physical injury and death. All electrical installation and maintenance work on the LR97D should be carried out by qualified electricians. Comply with the following to avoid serious personal injury before installing, setting, wiring, operating, repairing, removing, servicing, or checking unit :

- Always lock the off power switch.
- Comply with safety and health standards.
- Use it with care to prevent injury.
- Tools must be in good condition and properly used.
- Wiring must be done according to typical wiring diagram.

Type	Relay setting range
LR97D015	0.3 - 1.5 A
LR97D07	1.2 - 7 A
LR97D25	5 - 25 A
LR97D38	20 - 38 A



## Test / Stop Guide

TEST Function available at no load

- When LR97D is powered, keep Test button pushed for D-Time plus O-Time till internal relay switches its contact.
- Periodic test is recommended.

Stop Function while motor is running. Must be associated with 3-wire control circuit

- The motor will be stopped immediately by pressing the TEST/STOP button. In this case, LR97D is automatically reset.

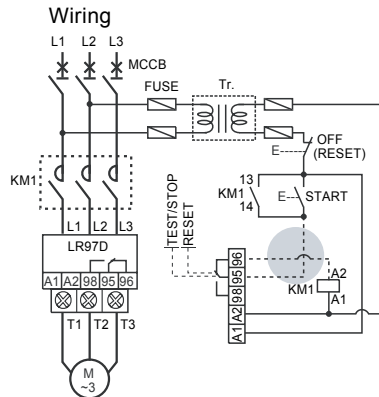

## Setting Guide

- In case machine operates its full load.
1. Adjust Load, D-Time and O-Time knobs to their maximum value. Then start motor.
  2. Adjust D-Time knob to the known motor start-up time. If start-up time is unknown, use clamp current meter to find its value.
  3. When motor reaches steady state, adjust Load knob counterclockwise until the red LED start to flicker. Then slowly adjust the Load knob clockwise until red LED stops flickering.
  4. Adjust O-Time knob to the desired trip delay time.
- In case load of machine is unknown or load with high fluctuation.
1. Adjust load knob to motor's nominal current or just upper value.
  2. Adjust D-Time to the calculated time which take into account the machine feature (Torque, Inertia)
  3. Adjust O-Time to desired trip relay time.

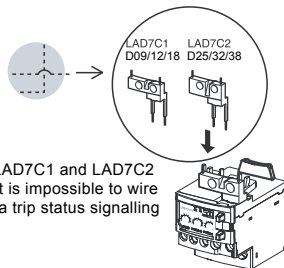

In case of LAD7C1 and LAD7C2 utilisation, it is impossible to wire electrically a trip status signalling

## Reset

- Manual: Immediate reset by RESET button
- Electrical: Immediate reset by interrupting control power, (minimum 0,1s). Remote electrical reset.
- Auto: 120 sec fixed, (Selectable using DIP SW. Over current trip only)

## Caution

- LR97D may be influenced by the harmonics on the control power.
- The control power should be supplied via the isolated transformer.
- Output : Normally energized.

## Adjustable Current Threshold(preset)

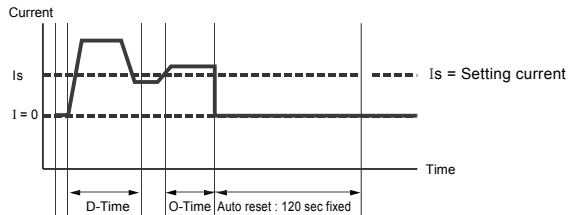

## Output Relay

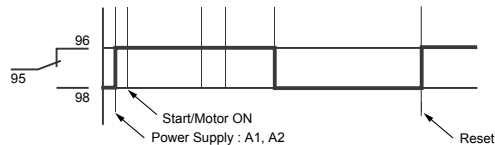

As shock relay utilisation, set O-Time at the minimum scale (tripping time: 0,2 ~ 0,3 s)