

---

|   |            |
|---|------------|
| <i>Presentation</i>   | 6          |
| <i>Functions and characteristics</i>                                  | 13         |
| <i>Dimensions and connection</i>                                      | 57         |
| <i>Electrical diagrams</i>  | 81         |
| <b>Compact NS100 to NS630</b>   | <b>96</b>  |
| Installation in switchboards  | 96         |
| Power connections   | 97         |
| Safety clearances and minimum distances                               | 99         |
| Temperature derating  | 100        |
| Power dissipation per pole  | 101        |
| Characteristics of circuit breakers with parallel connection of poles | 102        |
| <b>Masterpact NW10 to NW40</b>  | <b>104</b> |
| Installation in switchboard   | 104        |
| Door interlock catch  | 105        |
| Cable-type door interlock   |            |
| Connection of MN, MX and XF voltage releases                          | 106        |
| Power connection  | 107        |
| Busbar sizing   | 110        |
| Temperature derating  |            |
| Power dissipation and input / output resistance                       | 111        |
| <i>Additional characteristics</i>                                     | 113        |
| <i>Catalogue numbers and order form</i>                               | 135        |

### Possible mounting positions

For fixed or withdrawable circuit breakers

Fig. A

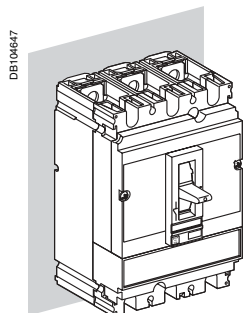

Fig. B

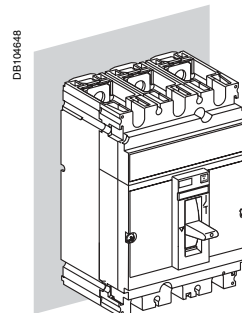

Fig. C

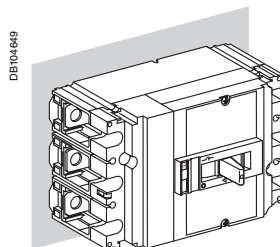

Fig. D

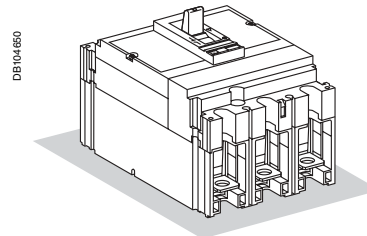
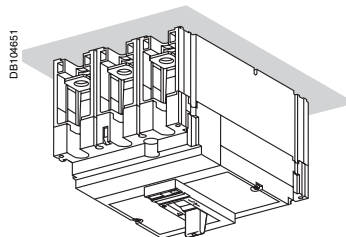

Fig. E



### Possible supports

For fixed or withdrawable circuit breakers

On a plain mounting plate

On a slotted mounting plate

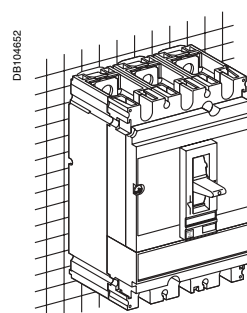
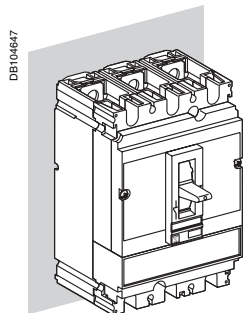

On rails

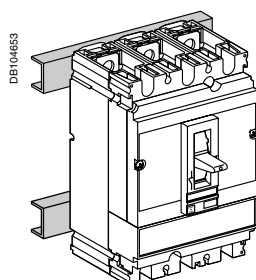

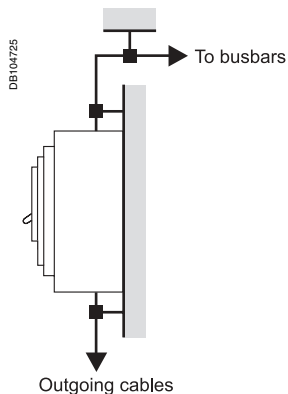

### Electrodynamic forces on the conductors

The circuit breakers can be connected with copper, tinned copper or tinned aluminum conductors (rigid or flexible bars, cables).

In the event of a short-circuit, electrodynamic forces will be exerted on the conductors.

They must therefore be correctly sized and maintained in place using supports.

Electrical connection points on all types of devices (contactors, circuit breakers, etc.) should not be used for mechanical support.

### Ties for flexible bars and cables

The table below indicates the maximum distance between ties depending on the prospective short-circuit current.

The maximum distance between ties attached to the switchboard frame is 400 mm.

| Type of tie         | Maximum distance between ties (mm) | Short-circuit current (kA rms) |
|---------------------|------------------------------------|--------------------------------|
| "PANDUIT" type ties | 200                                | 10                             |
| Width: 4.5 mm       | 100                                | 14                             |
| Max. load: 22 kg    | 50                                 | 19                             |
| White               |                                    |                                |
| "SAREL" type ties   | 350                                | 21                             |
| Width: 9 mm         | 200                                | 27                             |
| Max. load: 90 kg    | 100                                | 36                             |
| Black               | 70                                 | 45                             |
| Double ties         | 50                                 | 100                            |

**Note:** For 50 mm<sup>2</sup> cables, use the 9 mm wide ties.

### Weights

| Type        | Circuit breaker | Plug-in base | Chassis | Motor mechanism |
|-------------|-----------------|--------------|---------|-----------------|
| NS100N/H    | 1P/1D           | 0.5          | -       | -               |
|             | 2P/2D           | 1.45         | -       | -               |
| NS100DC     | 3P/3D           | 1.79         | 0.8     | 2.2             |
|             | 4P/4D           | 2.57         | 1.05    | 2.2             |
| NS160N/H    | 1P/1D           | 0.5          | -       | -               |
|             | 2P/2D           | 1.45         | -       | -               |
| NS160N/DC   | 3P/3D           | 1.85         | 0.8     | 2.2             |
|             | 4P/4D           | 2.58         | 1.05    | 2.2             |
| NS250DC     | 3P/3D           | 2.2          | 0.8     | 2.2             |
|             | 4P/4D           | 2.78         | 1.05    | 2.2             |
| NS400/630DC | 3P/3D           | 6.19         | 2.4     | 2.2             |
|             | 4P/4D           | 8.13         | 2.8     | 2.2             |

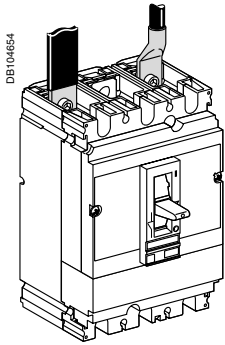

### Connection of insulated bars or cables with lugs

|             | NS100  | NS160/250 | NS400/630  |
|-------------|--------|-----------|------------|
| <b>Bars</b> |        |           |            |
| L (mm)      | ≤ 25   | ≤ 25      | ≤ 32       |
| l (mm)      | d + 10 | d + 10    | d + 15     |
| d (mm)      | ≤ 10   | ≤ 10      | ≤ 15       |
| e (mm)      | ≤ 6    | ≤ 6       | 3 ≤ e ≤ 10 |
| Ø (mm)      | 6.5    | 8.5       | 10.5       |

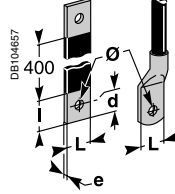

|  |        |      |      |      |
|--|--------|------|------|------|
| <b>Lugs</b>                                  | L (mm) | ≤ 25 | ≤ 25 | ≤ 32 |
|  | Ø (mm) | 6.5  | 8.5  | 10.5 |
| <b>Tightening torque (Nm) <sup>(1)</sup></b> |        | 10   | 15   | 50   |
| <b>Tightening torque (Nm) <sup>(2)</sup></b> |        | 5    | 5    | 20   |

(1) Tightening torque for lugs or bars on the circuit breaker.  
(2) Tightening torque for rear connections or terminal extensions on plug-in base.

### Connection of bare cables

#### NS100 to 250

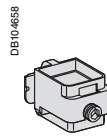
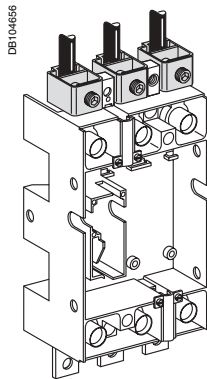
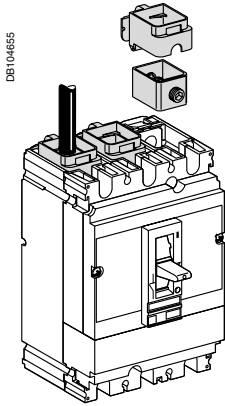

Cable connector.

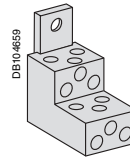

Distribution connector.

|   | Cable connector          | Steel    | Aluminium |                               |
|---|--------------------------|----------|-----------|-------------------------------|
|   |                          | ≤ 160 A  | ≤ 250 A   |                               |
| L (mm)  | 20                       | 20       |           |                               |
| S (mm <sup>2</sup> ) Cu/Al                                  | 1.5... 95 <sup>(1)</sup> | 10... 16 | 25... 35  | 50...185<br>150 max. flexible |
| Tightening torque (Nm)                                      | 12                       | 15       | 20        | 26                            |
| <b>6-cable distribution connector (copper or aluminium)</b> |                          |          |           |                               |
| L (mm)  |                          | 15 or 30 |           |                               |
| S (mm <sup>2</sup> ) Cu/Al                                  | 1.5... 6 <sup>(1)</sup>  | 8... 35  |           |                               |
| Tightening torque (Nm)                                      | 4                        | 6        |           |                               |

(1) For flexible cables from 1.5 to 4 mm<sup>2</sup>, connection with crimped or self-crimping ferrule.

#### NS400 to 630



Cable connector.

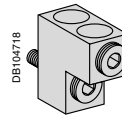

Distribution connector.

|                            | Cable connector                      | 2-cable connector                            |
|----------------------------|--------------------------------------|--|
| L (mm)                     | 20                                   | 30 or 60                                     |
| S (mm <sup>2</sup> ) Cu/Al | 35 to 300 rigid<br>240 max. flexible | 2 x 85 to 2 x 240 rigid<br>240 max. flexible |
| Tightening torque (Nm)     | 31                                   | 31   |



# Compact NS100 to NS630

## Safety clearances and minimum distances

When installing a Compact NS100 to NS630 circuit breaker, minimum distances (safety clearances) must be maintained between the device and panels, bars and other protection devices installed nearby. These distances, which depend on the ultimate breaking capacity, are defined by tests carried out in accordance with standard IEC 60947-2.

If installation conformity is not checked by type tests, it is also necessary to:

- use insulated bars for circuit-breaker connections
- block off the busbars using insulating screens.

Terminal shields, interphase barriers and the insulation kit are recommended and may be mandatory depending on the utilisation voltage and the type of installation (fixed, withdrawable).

### Minimal distance between two adjacent circuit breakers

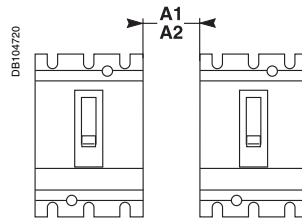

### Minimal distance between the circuit breaker and top, bottom or side panels

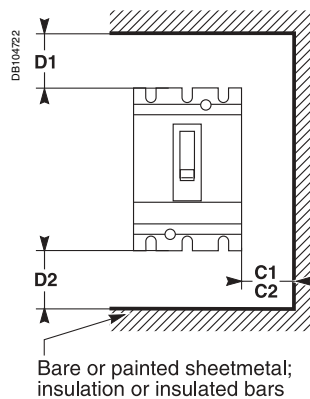

### Minimal distance between the circuit breaker and front or rear panels

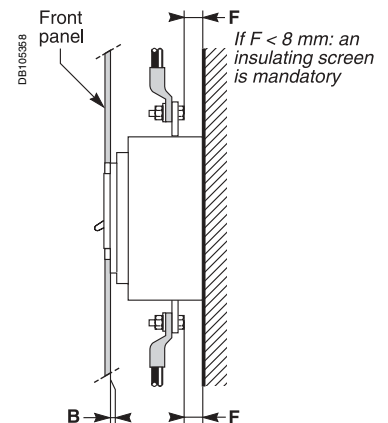

| Dimensions (mm)                | Insulation, insulated bars or painted sheet metal |    |    | Bare sheetmetal   |     |     | A1 <sup>(2)</sup> | A2 <sup>(3)</sup> | B |
|--------------------------------|---|----|----|-------------------|-----|-----|-------------------|-------------------|---|
|                                | C1  | D1 | D2 | C2                | D1  | D2  |                   |                   |   |
| <b>Compact circuit breaker</b> |   |    |    |                   |     |     |                   |                   |   |
| <b>NS100-250</b>               |   |    |    |                   |     |     |                   |                   |   |
| U ≤ 250 V                      | 0   | 30 | 30 | 5                 | 35  | 35  | 0                 | 10                | 0 |
| U ≤ 500 V                      | 0   | 30 | 30 | 10 <sup>(1)</sup> | 35  | 35  | 0                 | 20                | 0 |
| U ≤ 750 V                      | 0   | 30 | 30 | 20 <sup>(1)</sup> | 35  | 35  | 0                 | 40                | 0 |
| <b>NS400-630</b>               |   |    |    |                   |     |     |                   |                   |   |
| U ≤ 250 V                      | 0   | 30 | 30 | 5                 | 60  | 60  | 0                 | 10                | 0 |
| U ≤ 500 V                      | 0   | 30 | 30 | 10 <sup>(1)</sup> | 60  | 60  | 0                 | 20                | 0 |
| U ≤ 750 V                      | 0   | 30 | 30 | 20 <sup>(1)</sup> | 100 | 100 | 0                 | 40                | 0 |

<sup>(1)</sup> Distance must be doubled with interphase barriers.

<sup>(2)</sup> For Compact NS with long or short terminal shields.

<sup>(3)</sup> For Compact NS without terminal shields.

The mandatory distances when installing Compact NS circuit breakers are calculated from the device case, not taking into account the terminal shields or the interphase barriers.

These values are valid for fixed and withdrawable circuit breakers with or without terminal shields.

When the ambient temperature is greater than 40 °C, overload-protection characteristics are slightly modified. To determine tripping times using time/current curves, use the values of the current indicated in the table below, corrected to take into account the ambient temperature.

### Compact NS DC temperature derating

| NS DC configuration                | Type of trip unit | Rating In (A) for a given temperature |                     |                     |                     |                     |                     |                     |
|------------------------------------|-------------------|---------------------------------------|---------------------|---------------------|---------------------|---------------------|---------------------|---------------------|
|                                    |                   | Ambient temp. 40 °C                   | Ambient temp. 45 °C | Ambient temp. 50 °C | Ambient temp. 55 °C | Ambient temp. 60 °C | Ambient temp. 65 °C | Ambient temp. 70 °C |
| NS100 N/H 1/2P 1P 250 V - 2P 500 V | TM16D             | 16                                    | 15.6                | 15.2                | 14.8                | 14.5                | 14                  | 13.8                |
|                                    | TM25D             | 25                                    | 24.5                | 24                  | 23.5                | 23                  | 22                  | 21                  |
|                                    | TM32D             | 32                                    | 31.3                | 30.5                | 30                  | 29.5                | 29                  | 28.5                |
|                                    | TM40D             | 40                                    | 39                  | 38                  | 37                  | 36                  | 35                  | 34                  |
|                                    | TM50D             | 50                                    | 49                  | 48                  | 47                  | 46                  | 45                  | 44                  |
|                                    | TM63D             | 63                                    | 61.5                | 60                  | 58                  | 57                  | 55                  | 54                  |
|                                    | TM80D             | 80                                    | 78                  | 76                  | 74                  | 72                  | 70                  | 68                  |
| NS160 N/H 1/2P 1P 250 V - 2P 500 V | TM100D            | 100                                   | 97.5                | 95                  | 92.5                | 90                  | 87.5                | 85                  |
|                                    | TM125D            | 125                                   | 122                 | 119                 | 116                 | 113                 | 109                 | 106                 |
| NS160 DC 3/4P ≤ 500 V              | TM160D            | 160                                   | 156                 | 152                 | 147                 | 144                 | 140                 | 136                 |
|                                    | TM16D             | 16.8                                  | 16.4                | 16                  | 15.5                | 15.2                | 14.7                | 14.5                |
| NS100 DC 3/4P ≤ 500 V              | TM25D             | 26.3                                  | 25.7                | 25.2                | 24.7                | 24.2                | 23.1                | 22.1                |
|                                    | TM32D             | 33.6                                  | 33                  | 32                  | 31.5                | 31                  | 30.5                | 30                  |
|                                    | TM40D             | 42                                    | 41                  | 40                  | 39                  | 38                  | 37                  | 36                  |
|                                    | TM50D             | 53                                    | 51                  | 50                  | 49                  | 48                  | 47                  | 46                  |
|                                    | TM63D             | 66                                    | 65                  | 63                  | 61                  | 60                  | 58                  | 57                  |
|                                    | TM80DC            | 84                                    | 82                  | 80                  | 78                  | 76                  | 74                  | 71                  |
|                                    | TM100DC           | 105                                   | 102                 | 100                 | 97                  | 95                  | 92                  | 89                  |
| NS160 DC 3/4P ≤ 500 V              | TM125DC           | 131                                   | 128                 | 125                 | 122                 | 119                 | 114                 | 111                 |
|                                    | TM160DC           | 168                                   | 164                 | 160                 | 154                 | 151                 | 147                 | 143                 |
| NS250 DC 3/4P ≤ 500 V              | TM200DC           | 210                                   | 205                 | 200                 | 194                 | 189                 | 184                 | 179                 |
|                                    | TM250DC           | 250                                   | 240                 | 235                 | 230                 | 220                 | 210                 | 200                 |
| NS100 DC 3/4P > 500 V              | TM16D             | 16                                    | 15.6                | 15.2                | 14.8                | 14.5                | 14                  | 13.8                |
|                                    | TM25D             | 25                                    | 24.5                | 24                  | 23.5                | 23                  | 22                  | 21                  |
|                                    | TM32D             | 32                                    | 31.3                | 30.5                | 30                  | 29.5                | 29                  | 28.5                |
|                                    | TM40D             | 40                                    | 39                  | 38                  | 37                  | 36                  | 35                  | 34                  |
|                                    | TM50D             | 50                                    | 49                  | 48                  | 47                  | 46                  | 45                  | 44                  |
|                                    | TM63D             | 63                                    | 61.5                | 60                  | 58                  | 57                  | 55                  | 54                  |
|                                    | TM80DC            | 80                                    | 78                  | 76                  | 74                  | 72                  | 70                  | 68                  |
| NS160 DC 3/4P > 500 V              | TM100DC           | 100                                   | 97.5                | 95                  | 92.5                | 90                  | 87.5                | 85                  |
|                                    | TM125DC           | 125                                   | 122                 | 119                 | 116                 | 113                 | 109                 | 106                 |
| NS250 DC > 500 V                   | TM160DC           | 160                                   | 156                 | 152                 | 147                 | 144                 | 140                 | 136                 |
|                                    | TM200DC           | 200                                   | 195                 | 190                 | 185                 | 180                 | 175                 | 170                 |
| NS250 DC > 500 V                   | TM250DC           | 230                                   | 225                 | 220                 | 210                 | 200                 | 190                 | 180                 |
|                                    | NS400 DC ≤ 500 V  | P1-P2                                 | 400                 | 400                 | 400                 | 400                 | 400                 | 400                 |
| NS400 DC > 500 V                   | P1-P2             | 400                                   | 400                 | 400                 | 400                 | 400                 | 400                 | 380                 |
| NS630 DC ≤ 500 V                   | P1-P2-P3          | 550                                   | 530                 | 510                 | 490                 | 470                 | 440                 | 420                 |
| NS630 DC > 500 V                   | P1-P2-P3          | 500                                   | 480                 | 460                 | 440                 | 420                 | 400                 | 380                 |

**Example:** a Compact NS100 DC equipped with a TM80DC trip unit has a rating of:  
 ■ 84 A at 40 °C  
 ■ 78 A at 55 °C.



# Compact NS100 to NS630

## Characteristics of circuit breakers with parallel connection of poles

When poles are connected in parallel, the trip unit corresponding to the maximum circuit breaker rating is never used, for safety reasons related to temperature rise. The heating conditions are modified. The table opposite indicates the new thermal ratings that should be used for 2P, 3P and 4P circuit breakers.

See example 2 on page 17

| Type of circuit breaker | Pole connections             | Type of trip unit | Equivalent rated current <sup>(1)</sup> In (A) at 40 °C | Magnetic threshold Im (A) ±20 % |
|-------------------------|------------------------------|-------------------|---|---------------------------------|
| <b>NS100</b>            |                              |                   |   |                                 |
| NS100 N/H 2-pole        | 2P in parallel               | TM16D             | 40  | 520                             |
|                         |                              | TM25D             | 63  | 800                             |
|                         |                              | TM32D             | 80  | 800                             |
|                         |                              | TM40D             | 100   | 1400                            |
|                         |                              | TM50D             | 125   | 1400                            |
|                         |                              | TM63D             | 158   | 1400                            |
|                         |                              | TM80D             | 200   | 1600                            |
| NS100 DC 3-pole         | 3P in parallel               | TM16D             | 58  | 780                             |
|                         |                              | TM25D             | 90  | 1200                            |
|                         |                              | TM32D             | 115   | 1650                            |
|                         |                              | TM40D             | 144   | 2100                            |
|                         |                              | TM50D             | 180   | 2100                            |
|                         |                              | TM63D             | 227   | 2100                            |
|                         |                              | TM80DC            | 288   | 2400                            |
|                         |                              | TM16G             | 58  | 240                             |
|                         |                              | TM25G             | 90  | 300                             |
|                         |                              | TM40G             | 144   | 300                             |
| NS100 DC 4-pole         | 4P in parallel               | TM16D             | 74  | 1040                            |
|                         |                              | TM25D             | 115   | 1600                            |
|                         |                              | TM32D             | 147   | 2200                            |
|                         |                              | TM40D             | 184   | 2800                            |
|                         |                              | TM50D             | 230   | 2800                            |
|                         |                              | TM63D             | 290   | 2800                            |
|                         |                              | TM80DC            | 368   | 3200                            |
|                         |                              | TM16G             | 74  | 320                             |
|                         |                              | TM25G             | 115   | 400                             |
|                         |                              | TM40G             | 184   | 400                             |
|                         | TM63G                        | 290               | 600   |                                 |
|                         | 2x2P (in parallel) in series | TM16D             | 37  | 520                             |
|                         |                              | TM25D             | 58  | 800                             |
|                         |                              | TM32D             | 74  | 1100                            |
|                         |                              | TM40D             | 46  | 1400                            |
|                         |                              | TM50D             | 115   | 1400                            |
|                         |                              | TM63D             | 145   | 1400                            |
|                         |                              | TM80DC            | 184   | 1600                            |
|                         |                              | TM16G             | 37  | 160                             |
|                         |                              | TM25G             | 58  | 200                             |
| TM40G                   |                              | 46                | 200   |                                 |
| TM63G                   | 145                          | 300               |   |                                 |
| <b>NS160</b>            |                              |                   |   |                                 |
| NS160 N/H 2-pole        | 2P in parallel               | TM125D            | 313   | 2400                            |
| NS160 DC 3-pole         | 3P in parallel               | TM100DC           | 360   | 2400                            |
|                         |                              | TM125DC           | 450   | 3750                            |
| NS160 DC 4-pole         | 4P in parallel               | TM100DC           | 460   | 3200                            |
|                         |                              | TM125DC           | 575   | 5000                            |
|                         | 2x2P (in parallel) in series | TM100DC           | 230   | 1600                            |
|                         |                              | TM125DC           | 288   | 2500                            |

See example 1 on page 17

(1) Rated current of the assembly with the indicated pole connections.

**Example** ■: a Compact NS100 DC 4-pole circuit breaker with 4 poles in parallel, equipped with a TM63D trip unit:

- an equivalent rated current of 290 A
- a fixed magnetic threshold of 2800 A.

# Compact NS100 to NS630

## Characteristics of circuit breakers with parallel connection of poles

| Type of circuit breaker | Pole connections             | Type of trip unit | Equivalent rated current <sup>(1)</sup> In (A) at 40 °C | Magnetic threshold Im (A) ±20 % |
|-------------------------|------------------------------|-------------------|---|---------------------------------|
| <b>NS250</b>            |                              |                   |   |                                 |
| NS250 DC 3-pole         | 2P in parallel               | TM160DC           | 400   | 2500                            |
|                         |                              | TM200DC           | 500   | 2000 to 4000                    |
| NS250 DC 3-pole         | 3P in parallel               | TM160DC           | 576   | 3750                            |
|                         |                              | TM200DC           | 720   | 3000 to 6000                    |
| NS250 DC 4-pole         | 4P in parallel               | TM160DC           | 736   | 5000                            |
|                         |                              | TM200DC           | 920   | 4000 to 8000                    |
|                         | 2x2P (in parallel) in series | TM160DC           | 368   | 2500                            |
|                         |                              | TM200DC           | 460   | 2000 to 4000                    |
| <b>NS400</b>            |                              |                   |   |                                 |
| NS400 DC 3-pole         | 2P in parallel               | MP1               | 640   | 1600 to 3200                    |
|                         |                              | MP2               | 640   | 2500 to 5000                    |
| NS400 DC 3-pole         | 3P in parallel               | MP1               | 960   | 2400 to 4800                    |
|                         |                              | MP2               | 960   | 3750 to 7500                    |
| NS400 DC 4-pole         | 4P in parallel               | MP1               | 1280  | 3200 to 6400                    |
|                         |                              | MP2               | 1280  | 5000 to 10000                   |
|                         | 2x2P (in parallel) in series | MP1               | 640   | 1600 to 3200                    |
|                         |                              | MP2               | 640   | 2500 to 5000                    |
| <b>NS630</b>            |                              |                   |   |                                 |
| NS630 DC 2-pole         | 2P in parallel               | MP1               | 1000  | 1600 to 3200                    |
|                         |                              | MP2               | 1000  | 2500 to 5000                    |
|                         |                              | MP3               | 1000  | 4000 to 8000                    |
| NS630 DC 3-pole         | 3P in parallel               | MP1               | 1500  | 2400 to 4800                    |
|                         |                              | MP2               | 1500  | 3750 to 7500                    |
|                         |                              | MP3               | 1500  | 6000 to 12000                   |
| NS630 DC 4-pole         | 4P in parallel               | MP1               | 2000  | 3200 to 6400                    |
|                         |                              | MP2               | 2000  | 5000 to 10000                   |
|                         |                              | MP3               | 2000  | 8000 to 16000                   |
|                         | 2x2P (in parallel) in series | MP1               | 1000  | 1600 to 3200                    |
|                         |                              | MP2               | 1000  | 2500 to 5000                    |
|                         |                              | MP3               | 1000  | 4000 to 8000                    |

## Possible positions

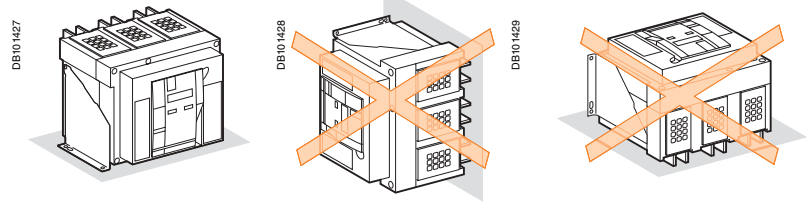

## Power supply

The plus and minus polarities (**LINE + and LINE -**) of the power supply must be connected as indicated in the "Dimensions and connection" chapter.

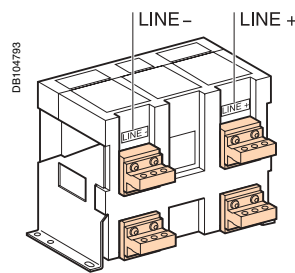

## Mounting the circuit-breaker

It is important to distribute the weight of the device uniformly over a rigid mounting surface such as rails or a base plate.

This mounting plane should be perfectly flat (tolerance on support flatness: 2 mm). This eliminates any risk of deformation which could interfere with correct operation of the circuit breaker.

Masterpact devices can also be mounted on a vertical plane using the special brackets.

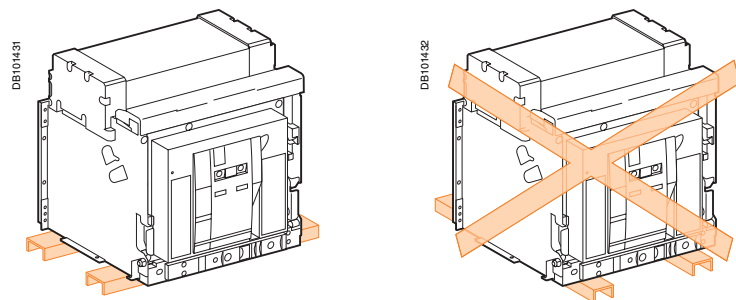

Mounting on rails.

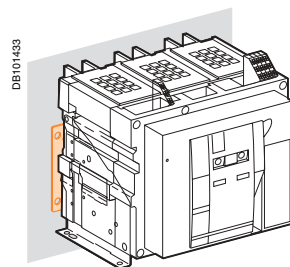

Mounting with vertical brackets.

Mounted on the right or left-hand side of the cradle, this device inhibits opening of the cubicle door when the circuit breaker is in "connected" or "test" position. If the breaker is put in the "connected" position with the door open, the door may be closed without having to disconnect the circuit breaker.

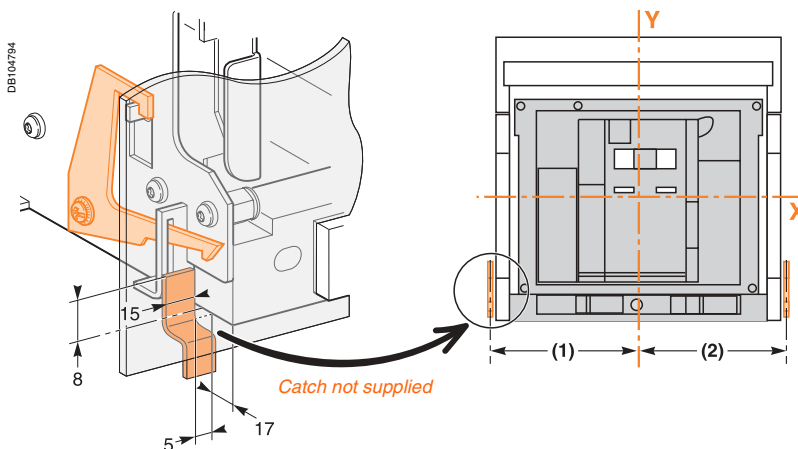

### Dimensions (mm)

| Type                   | (1) | (2) |
|------------------------|-----|-----|
| NW10-40 (versions C-D) | 215 | 215 |
| NW10-40 (version E)    | 330 | 215 |

### Breaker in "connected" or "test" position

Door cannot be opened

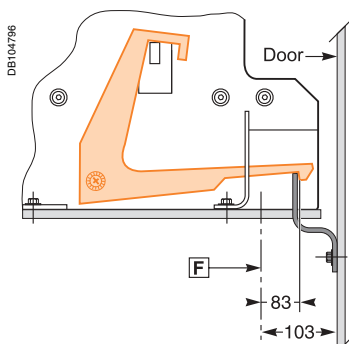

### Breaker in "disconnected" position

Door can be opened

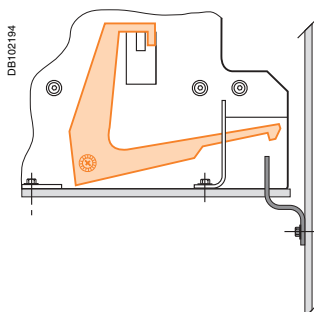

**Note:**  
The door interlock can either be mounted on the right side or the left side of the breaker.

**F:** Datum.

# Masterpact NW10 to NW40

## Cable-type door interlock

### Connection of MN, MX and XF voltage releases

#### Cable-type door interlock

This option prevents door opening when the circuit breaker is closed and prevents circuit breaker closing when the door is open.  
For this, a special plate associated with a lock and a cable is mounted on the right side of the circuit breaker.  
With this interlock installed, the source changeover function cannot be implemented.

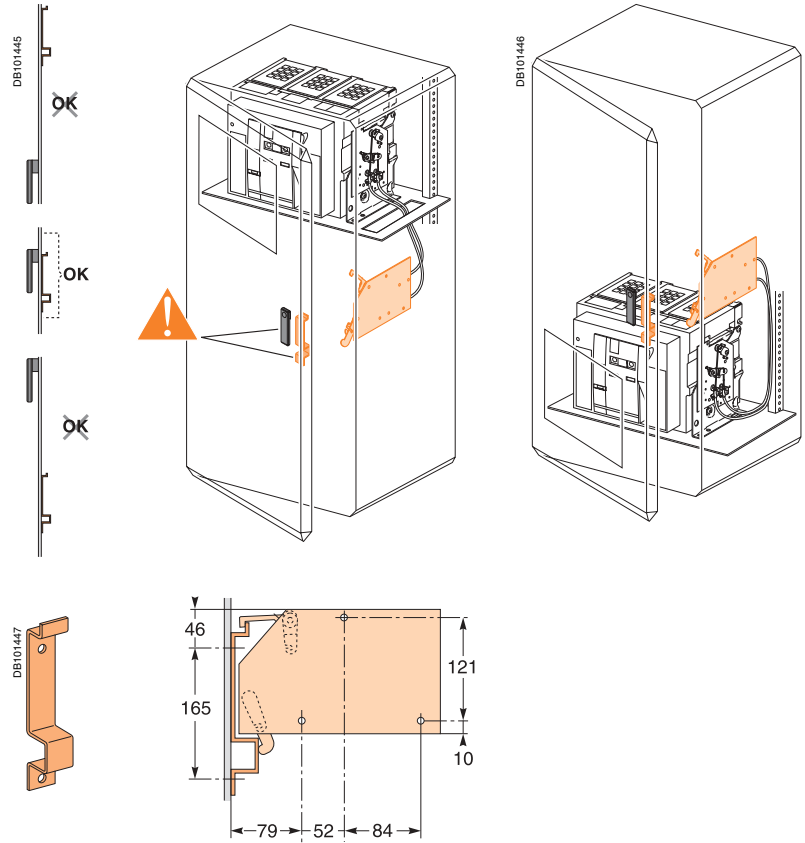

#### Wiring of voltage releases

During pick-up, the power consumed is approximately 150 to 200 VA. For low control voltages (12, 24, 48 V), maximum cable lengths are imposed by the voltage and the cross-sectional area of cables.

#### Recommended maximum cable lengths (meter)

|       |                | 12 V                |                     | 24 V                |                     | 48 V                |                     |
|-------|----------------|---------------------|---------------------|---------------------|---------------------|---------------------|---------------------|
|       |                | 2.5 mm <sup>2</sup> | 1.5 mm <sup>2</sup> | 2.5 mm <sup>2</sup> | 1.5 mm <sup>2</sup> | 2.5 mm <sup>2</sup> | 1.5 mm <sup>2</sup> |
| MN    | U source 100 % | -                   | -                   | 58                  | 35                  | 280                 | 165                 |
|       | U source 85 %  | -                   | -                   | 16                  | 10                  | 75                  | 45                  |
| MX-XF | U source 100 % | 21                  | 12                  | 115                 | 70                  | 550                 | 330                 |
|       | U source 85 %  | 10                  | 6                   | 75                  | 44                  | 350                 | 210                 |

*Note: the indicated length is that of each of the two wires.*

## Cable connections

If cables are used for the power connections, make sure that they do not apply excessive mechanical forces to the circuit breaker terminals.

For this, make the connections as follows:

- extend the circuit breaker terminals using short bars designed and installed according to the recommendations for bar-type power connections:
  - for a single cable, use solution **B** opposite
  - for multiple cables, use solution **C** opposite.
- in all cases, follow the general rules for connections to busbars:
  - position the cable lugs before inserting the bolts
  - the cables should firmly secured to the framework of the switchboard (**E**).

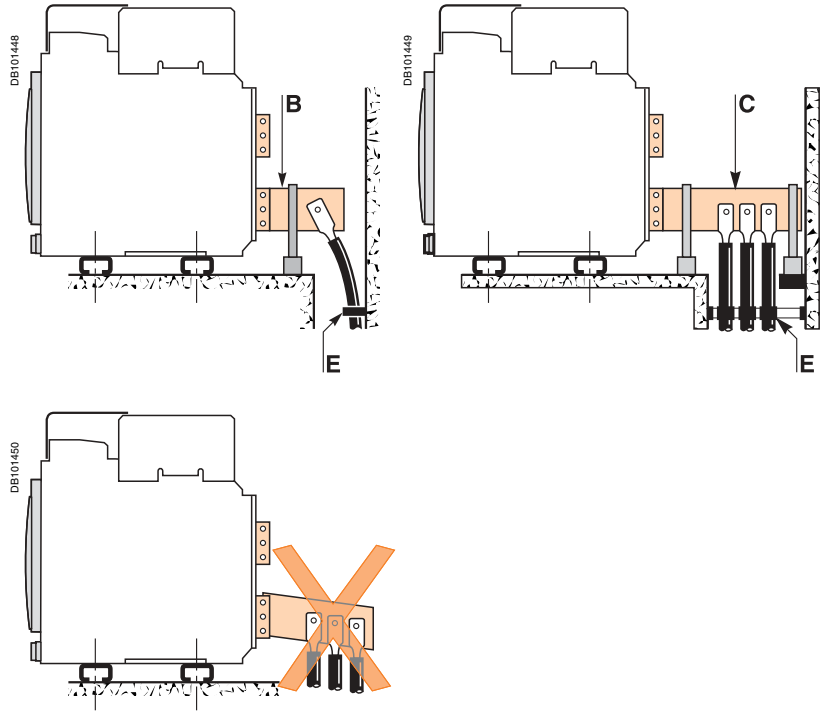

## Busbar connections

The busbars should be suitably adjusted to ensure that the connection points are positioned on the terminals before the bolts are inserted **B**.

The connections are held by the support which is solidly fixed to the framework of the switchboard, such that the circuit breaker terminals do not have to support its weight **C**. (This support should be placed close to the terminals).

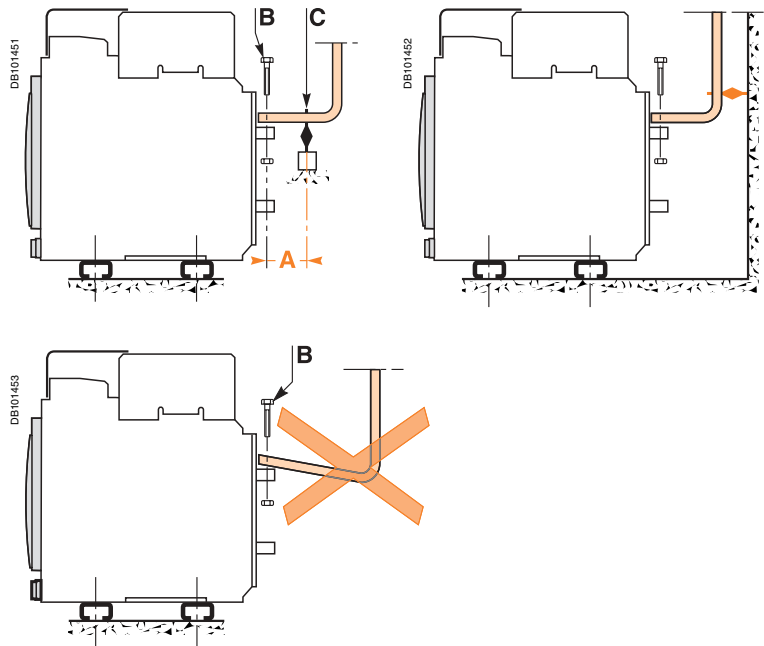

## Electrodynamic stresses

The first busbar support or spacer shall be situated within a maximum distance from the connection point of the breaker (see table below). This distance must be respected so that the connection can withstand the electrodynamic stresses between phases in the event of a short circuit.

Maximum distance A between busbar to circuit breaker connection and the first busbar support or spacer with respect to the value of the prospective short-circuit current.

| I <sub>sc</sub> (kA) | 30  | 50  | 65  | 80  | 100 |
|----------------------|-----|-----|-----|-----|-----|
| distance A (mm)      | 350 | 300 | 250 | 150 | 150 |

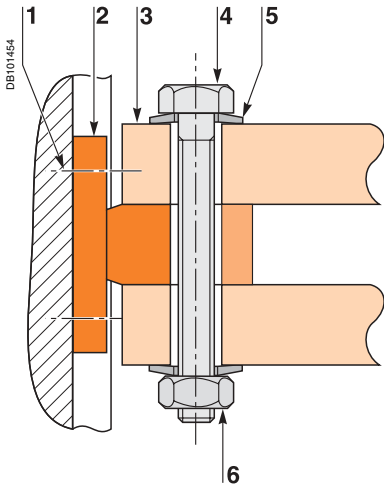

- 1 Terminal screw factory-tightened to 16 Nm.
- 2 Breaker terminal.
- 3 Busbar.
- 4 Bolt.
- 5 Washer.
- 6 Nut.

## Clamping

Correct clamping of busbars depends amongst other things, on the tightening torques used for the nuts and bolts. Over-tightening may have the same consequences as under-tightening.

For connecting busbars (Cu ETP-NFA51-100) to the circuit breaker, the tightening torques to be used are shown in the table below.

These values are for use with copper busbars and steel nuts and bolts, class 8.8. The same torques can be used with AGS-T52 quality aluminium bars (French standard NFA 02-104 or American National Standard H-35-1).

## Examples

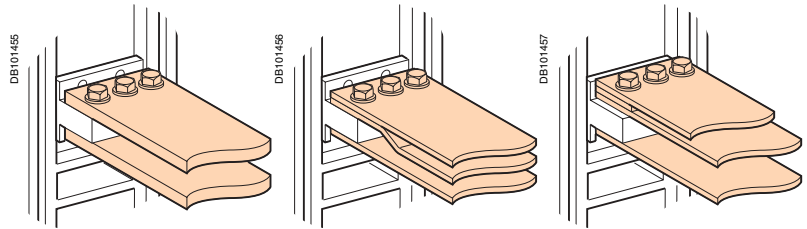

### Tightening torques

| Ø<br>Nominal (mm) | Ø<br>Drilling (mm) | Tightening torque (Nm)<br>with flat washers or<br>split lockwashers | Tightening torque<br>(Nm) with contact<br>or serrated washers |
|-------------------|--------------------|---|---|
| 10                | 11                 | 37.5  | 50  |

## Busbar drilling

### Examples

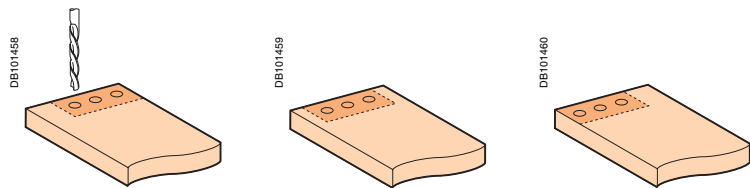

## Isolation distance

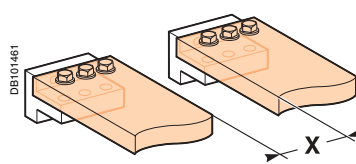

### Dimensions (mm)

| Ui       | X mini |
|----------|--------|
| 500 V DC | 8 mm   |
| 900 V DC | 14 mm  |

## Busbar bending

When bending busbars maintain the radius indicated below (a smaller radius would cause cracks).

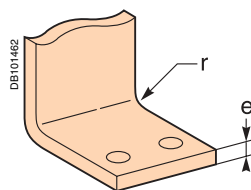

### Dimensions (mm)

| e  | Radius of curvature r |             |
|----|-----------------------|-------------|
|    | Min.                  | Recommended |
| 5  | 5                     | 7.5         |
| 10 | 15                    | 18 to 20    |

## Horizontal rear connection NW10 to NW20 DC

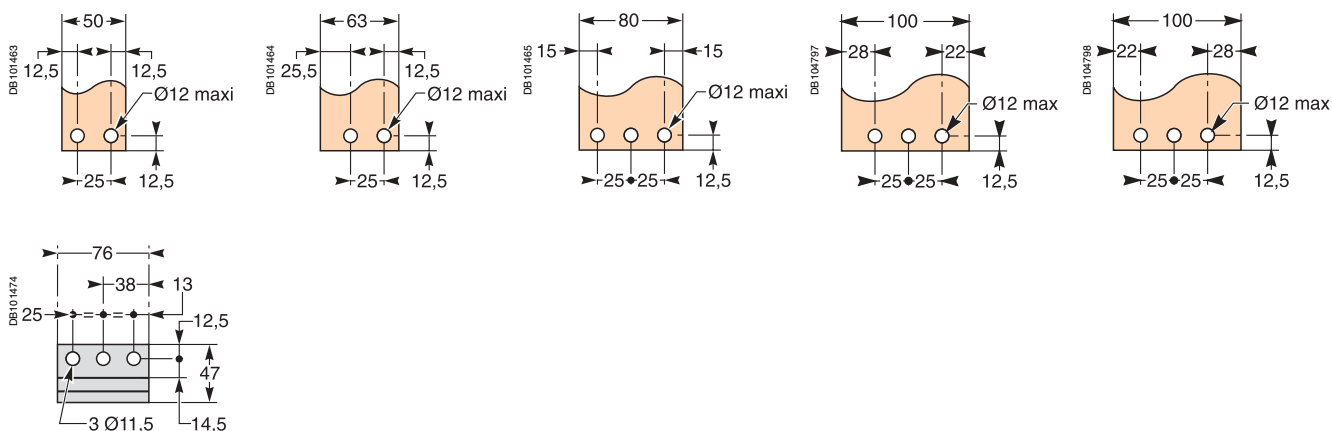

## Vertical rear connection NW10 to NW20 DC

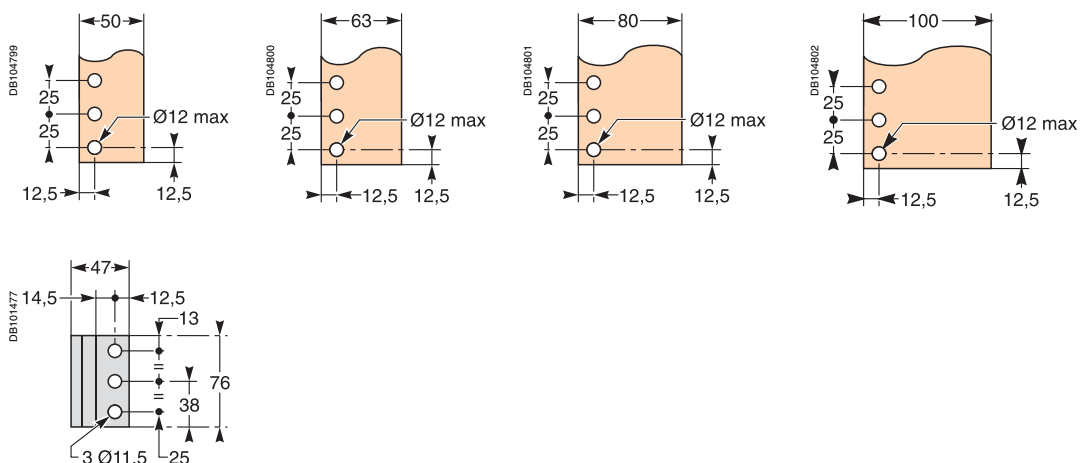

## Vertical rear connection NW40 DC

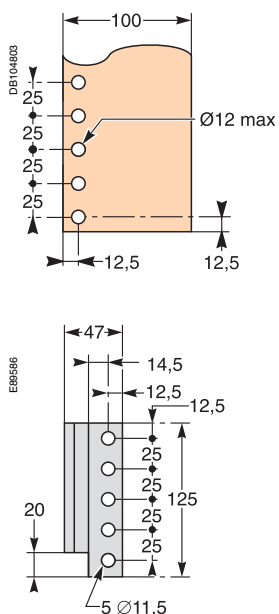

DB101487

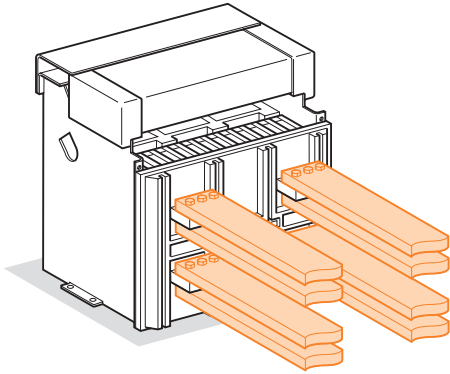

## Rear horizontal connection

### Basis of tables

- maximum permissible busbar temperature: 100 °C
- Ti: temperature around the circuit breaker and its connections
- busbar material is unpainted copper.

### Example

Conditions:

- drawout version
- horizontal busbars
- Ti: 50 °C
- service current: 2000 A.

### Solution

For Ti = 50 °C, use an NW20 DC which can be connected with three 100 x 5 mm bars or two 80 x 10 mm bars.

| Masterpact | Maximum service current | Ti: 40 °C<br>no. of bars |                  | Ti: 50 °C<br>no. of bars |                  | Ti: 60 °C<br>no. of bars |                  |
|------------|-------------------------|--------------------------|------------------|--------------------------|------------------|--------------------------|------------------|
|            |                         | 5 mm thick bars          | 10 mm thick bars | 5 mm thick bars          | 10 mm thick bars | 5 mm thick bars          | 10 mm thick bars |
| NW10       | 1000                    | 3b.50 x 5                | 1b.63 x 10       | 3b.50 x 5                | 2b.50 x 10       | 3b.63 x 5                | 2b.50 x 10       |
| NW20       | 2000                    | 3b.100 x 5               | 2b.80 x 10       | 3b.100 x 5               | 2b.80 x 10       | 3b.100 x 5               | 3b.63 x 10       |

**Note:** the values indicated in these tables have been extrapolated from test data and theoretical calculations. These tables are only intended as a guide and cannot replace industrial experience or a temperature rise test.

DB101484

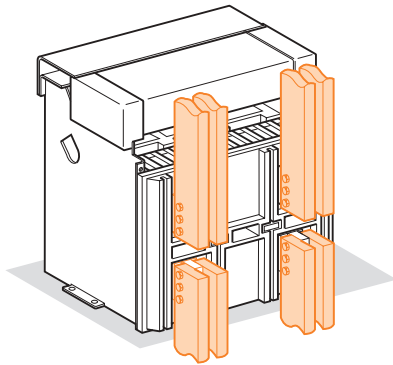

## Rear vertical connection

### Basis of tables

- maximum permissible busbar temperature: 100 °C
- Ti: temperature around the circuit breaker and its connections
- busbar material is unpainted copper.

### Example

Conditions:

- fixed version
- vertical busbars
- Ti: 40 °C
- service current: 1000 A.

### Solution

For Ti = 40 °C, use an NW10 DC which can be connected with two 50 x 5 mm bars or one 50 x 10 mm bar.

| Masterpact | Maximum service current | Ti: 40 °C<br>no. of bars |                  | Ti: 50 °C<br>no. of bars |                  | Ti: 60 °C<br>no. of bars |                  |
|------------|-------------------------|--------------------------|------------------|--------------------------|------------------|--------------------------|------------------|
|            |                         | 5 mm thick bars          | 10 mm thick bars | 5 mm thick bars          | 10 mm thick bars | 5 mm thick bars          | 10 mm thick bars |
| NW10       | 1000                    | 2b.50 x 5                | 1b.50 x 10       | 2b.50 x 5                | 1b.50 x 10       | 2b.63 x 5                | 1b.63 x 10       |
| NW20       | 2000                    | 2b.100 x 5               | 2b.63 x 10       | 2b.100 x 5               | 2b.63 x 10       | 3b.100 x 5               | 3b.80 x 10       |
| NW40       | 4000                    | -                        | 4b.100 x 10      | -                        | 4b.100 x 10      | -                        | 4b.100 x 10      |

**Note:** the values indicated in these tables have been extrapolated from test data and theoretical calculations. These tables are only intended as a guide and cannot replace industrial experience or a temperature rise test.

# Masterpact NW10 to NW40

## Temperature derating Power dissipation and input / output resistance

### Temperature derating

The table below indicates the maximum current rating, for each connection type, as a function of the ambient temperature around the circuit breaker and the busbars. For ambient temperatures greater than 60 °C, consult us.

Ti: temperature around the circuit breaker and its connections.

| Version             | Drawout device  |    |    |    |    |               |    |      |    |      | Fixed device    |      |    |    |    |               |    |    |      |    |  |  |  |
|---------------------|-----------------|----|----|----|----|---------------|----|------|----|------|-----------------|------|----|----|----|---------------|----|----|------|----|--|--|--|
|                     | Rear horizontal |    |    |    |    | Rear vertical |    |      |    |      | Rear horizontal |      |    |    |    | Rear vertical |    |    |      |    |  |  |  |
| Connection temp. Ti | 40              | 45 | 50 | 55 | 60 | 40            | 45 | 50   | 55 | 60   | 40              | 45   | 50 | 55 | 60 | 40            | 45 | 50 | 55   | 60 |  |  |  |
| NW10 Version C      | 1000            |    |    |    |    | 1000          |    |      |    |      | 1000            |      |    |    |    | 1000          |    |    |      |    |  |  |  |
| Version D           | 1000            |    |    |    |    | 1000          |    |      |    |      | 1000            |      |    |    |    | 1000          |    |    |      |    |  |  |  |
| Version E           | 1000            |    |    |    |    | 1000          |    |      |    |      | 1000            |      |    |    |    | 1000          |    |    |      |    |  |  |  |
| NW20 Version C      | 2000            |    |    |    |    | 2000          |    |      |    |      | 2000            |      |    |    |    | 2000          |    |    |      |    |  |  |  |
| Version D           | 2000            |    |    |    |    | 2000          |    |      |    |      | 2000            |      |    |    |    | 2000          |    |    |      |    |  |  |  |
| Version E           | 2000            |    |    |    |    | 2000          |    |      |    |      | 2000            |      |    |    |    | 2000          |    |    |      |    |  |  |  |
| NW40 Version C      | -               |    |    |    |    | 4000          |    |      |    |      | -               |      |    |    |    | 4000          |    |    |      |    |  |  |  |
| Version D           | -               |    |    |    |    | 4000          |    | 3900 |    | 3750 |                 | 3600 |    | -  |    |               |    |    | 4000 |    |  |  |  |
| Version E           | -               |    |    |    |    | 4000          |    | 3800 |    | 3650 |                 | 3500 |    | -  |    |               |    |    | 4000 |    |  |  |  |

### Power dissipation and input/output resistance

Total power dissipation is the value measured at I<sub>N</sub>, for a 3 pole (version C, D) or 4 pole (version E) breaker (values above the power  $P = 3RI^2$ ).

The resistance between input / output is the value measured per pole (cold state).

| Version | Drawout device           |     |      |                               |    |     | Fixed device             |     |     |                               |    |    |
|---------|--------------------------|-----|------|-------------------------------|----|-----|--------------------------|-----|-----|-------------------------------|----|----|
|         | Power dissipation (Watt) |     |      | Input/output resistance (µhm) |    |     | Power dissipation (Watt) |     |     | Input/output resistance (µhm) |    |    |
| version | C                        | D   | E    | C                             | D  | E   | C                        | D   | E   | C                             | D  | E  |
| NW10    | 45                       | 75  | 105  | 46                            | 73 | 102 | 25                       | 40  | 60  | 22                            | 40 | 58 |
| NW20    | 135                      | 230 | 330  | 34                            | 58 | 82  | 90                       | 160 | 235 | 22                            | 40 | 58 |
| NW40    | 460                      | 800 | 1150 | 29                            | 50 | 72  | 360                      | 580 | 850 | 22                            | 36 | 52 |

